

# DRAINAGE REPORT

Brindley Residence  
7810 79<sup>th</sup> Ave SE, Mercer Island, 98040

City of Mercer Island Permit No. 2203-116-SUB1



Prepared by:



**HL** ENGINEERING

~~March 2, 2022~~

~~July 22, 2022~~

September 20, 2022

## Contents

1. INTRODUCTION
  2. MINIMUM REQUIREMENTS
  3. ON-SITE STORMWATER MANAGEMENT
  4. FLOW CONTROL
  5. CONVEYANCE SYSTEM ANALYSIS
- Appendix A DOE Flowchart for Determining Requirements For New Dev
  - Appendix B Infiltration Feasibility Map
  - Appendix C Western Washington Hydrology Model (WWHM) Output
  - Appendix D Stormwater Plan
  - Appendix E Stormwater Pump System Calculations
  - Appendix F Operations and Maintenance Standards

## 1. INTRODUCTION:

These calculations and report document the storm drainage design for the single-family residential development project located at an un-addressed parcel on 79<sup>th</sup> Avenue SE in the City of Mercer Island.

The calculations and report have been prepared by HL Engineering for submittal of the building permit application, and in compliance with the City of Mercer Island's Stormwater Requirements (based on the Department of Ecology's 2014 Stormwater Management Manual for Western Washington).

The project is located on the east side of 79<sup>th</sup> Ave SE (see Figure 1). The site is surrounded on the north, south, and east by single family developments. The site is currently vacant as consists of a well-maintained lawn and several trees.



Figure 1: Location Map

The project improvements include the following:

- Removal of non-exceptional trees and fencing. The project proposes to re-use a stubbed sanitary side sewer.
- Construction of a new residential structure, along with walkways and driveway, along with Installation of service utilities, and an underground detention vault for roof stormwater runoff as a Best Management Practice (BMP).

See Appendix C for the Stormwater Plan, highlighted to show BMPs and proposed compliance.

## 2. MINIMUM REQUIREMENTS:

The project proposes one residential dwelling unit, with a total New + Replaced Hard Surface Footprint of 11,850 sf in a vacant / undeveloped parcel. As such, the minimum requirements for the project are summarized in Table 1.

Table 1. Minimum Stormwater Requirements for Parcel-Based Projects:

Minimum Requirement (MR) Description	Code Section	Applicability
Preparation of Stormwater Site Plan	1-3.4.1 MR1	Applies
Construction Stormwater Pollution Prevention Plan	1-3.4.2 MR2	Applies
Source Control of Pollution	1-3.4.3 MR3	Applies
Preservation of Natural Drainage Systems	1-3.4.4 MR4	Applies
On-Site Stormwater Management	1-3.4.5 MR5	Applies
Runoff Treatment	1-3.4.6 MR6	Applies
Flow Control	1-3.4.7 MR7	Applies
Wetlands Protection	1-3.4.8 MR8	Applies
Operations and Maintenance	1-3.4.9 MR9	Applies

This report will discuss the requirements that impact the strategy, selection, and sizing of proposed stormwater BMPs.

## **2.1 MR1: PREPARATION OF STORMWATER SITE PLAN**

As a project that exceeds the 2,000 sf threshold of hard surfaces, the project is required to prepare Stormwater Site Plans. The permit drawings C4.00, C4.50, C4.60, and C4.70 provide stormwater system layouts and details for the project.

The stormwater system includes not only piping and detention system but also oil/water separation for pollutant-generating surfaces and a pump system to lift stormwater runoff from the detention tank to the shallow City main in 79<sup>th</sup> Avenue SE.

## **2.2 MR2: CONSTRUCTION STORMWATER POLLUTION PREVENTION PLAN**

The project exceeds the 2,000 sf threshold for preparation of Construction phase Stormwater Pollution Prevention Plans. Erosion and Sedimentation Control plan Sheets C1.00, C1.50 are included in the permit drawings, which would be used by the contractor as part of a completed SWPPP.

Temporary erosion and sedimentation control measures proposed for this project include silt fence, straw wattles, and a stabilized construction entrance.

## **2.3 MR3: SOURCE CONTROL OF POLLUTION**

The project site is vacant in the existing condition. There are no known tanks or soil contaminations that would require mitigation or protection in order to provide source control of those pollutants.

## **2.4 MR4: PRESERVATION OF NATURAL DRAINAGE SYSTEM**

The existing site topography indicates sheet flow drainage to the west (to the public right of way of 79<sup>th</sup> Avenue SE). The City's public storm drain main in 79<sup>th</sup> Avenue SE is the approved point of discharge for the project and for neighboring properties, given that the site has no ability to infiltrate stormwater and does not have the size to provide dispersion systems. The project will convey stormwater flow to the existing storm main in 79<sup>th</sup> Avenue SE.

## 2.5 MR5: ONSITE STORMWATER MANAGEMENT

On-site Stormwater Management is required for this project, and the specific requirement is to comply with LID Performance Standard:

*“Stormwater discharges shall match developed discharge durations to pre-developed durations for the range of pre-developed discharge rates from 8% of the 2-year peak flow to 50% of the 2-year peak flow. Refer to the Flow Control Performance Standard section in I-3.4.7 MR7: Flow Control for information about the assignment of the pre-developed condition. Project sites that must also meet I-3.4.7 MR7: Flow Control must match flow durations between 8% of the 2-year flow through the full 50-year flow.”*

The pre-developed condition is the forested condition, per SWMMWW Section I-3.4.7 “MR7: Flow Control”, since the project site and downstream areas are estimated to have a Total Impervious Area of less than 40% since 1985.

Ideally a project could use infiltration techniques to comply with this Requirement, as the City of Mercer Island Infiltration Feasibility Map (Appendix B) indicates moderate infiltration potential at the site. However, the project geotechnical engineer (Geotech Consultants, Inc) concluded in their September 2, 2021 Geotechnical Engineering Study:

*Often, the impermeable nature of the glacial till causes a shallow seasonal perched water table to form where the ground surface is not covered by an impervious layer. This is a common problem in the wet season throughout the Pacific Northwest. Considering this, and because the upper soil at the site is generally fill soil that cannot be used to infiltrate into, it is our professional opinion that onsite infiltration of stormwater is not feasible for the subject site.*

The project reviewed the List Approach for MR5 Compliance (Table 1-3.2) within the SWMMWW for this project site, which is not considered to be exempt from Flow Control and is subject to MR #1 through MR #9, with the following conclusions in regards to options for stormwater BMPs:

Lawn and Landscape:

1. Post-Construction Soil Quality and Depth

Feasible and implemented

Roofs:

1. Full Dispersion -or- Downspout Full Infiltration  
**Not Feasible** – Site cannot infiltrate, and site does not have dispersion area of 6.5 x the hard surface area or a 50' flow path available within disturbed limits
2. Bioretention  
**Not Feasible** – the project's professional geotechnical evaluation recommends infiltration not be used
3. Downspout Dispersion Systems  
**Not Feasible** – 50' flow path is not available onsite
4. Perforated Stub-Out Connections  
**Not Feasible** – the project's professional geotechnical evaluation recommends infiltration not be used
5. On-Site Detention (MICC 15.09.050)  
**Feasible and implemented**

Other Hard Surfaces:

1. Full Dispersion  
**Not Feasible** – Site cannot infiltrate, and site does not have dispersion area of 6.5 x the hard surface area or a 50' flow path available within disturbed limits
2. Permeable Pavements  
**Not Feasible** – the project's professional geotechnical evaluation recommends infiltration not be used
3. Bioretention  
**Not Feasible** – the project's professional geotechnical evaluation recommends infiltration not be used
4. Sheet Flow Dispersion -or- Concentrated Flow Dispersion

**Not Feasible – the project site does not have space for a 10’-wide vegetated buffer and 2’-wide transition zone downstream of the paved areas (largely due to tree protection zones)**

5. On-Site Detention (MICC 15.09.050)  
**Feasible and implemented**

The selected On-Site Stormwater management mitigation for the project is a combination of below-grade detention system and Post-Construction Soil Quality and Depth. The Predeveloped and Mitigated flow rates are discussed more under MR7 “Flow Control” below.

**\*\* NOTE:** Because the MR5 BMPs listed in the SWMMWW for Roof and Other Hard Surfaces are all determined to be infeasible, the actual flow release requirement will be based on MR7 requirements as noted below.

## **2.6 MR6: RUNOFF TREATMENT**

Although this project proposes a total of 11,850 sf of New + Replaced Hard Surfaces, the area of Pollution-Generating Hard Surface (PGHS) consists only of the driveway, which is 2,310 sf. In accordance with the SWMMWW Section I-3.4.6 “Runoff Treatment”, this project falls below the threshold for Treatment requirements.

In addition to the requirements of the SWMMWW, the City of Mercer Island Municipal Code Section 15.09.050.A requires passive spill control for driveways. As such, **this project proposes a French drain system to collect all driveway runoff, which then conveys to a 100 gallon proprietary, private oil / water separation unit.** The flow is then conveyed to the below-grade detention vault.

## **2.7 MR7: FLOW CONTROL**

The project is required to achieve the Flow Control Performance Standard for the New + Replaced Hard Surfaces, for which the following must be met:

*Stormwater discharges shall match developed discharge durations to pre-developed durations for the range of pre-developed discharge rates from 50% of the 2-year peak flow up to the full 50-year peak flow.*



When coupled with the requirements noted under MR5, the project is required to match flow durations between 8% of the 2-year flow through the full 50-year flow.

Given the inability to infiltrate stormwater, the project is providing detention to the maximum extent feasible to comply with the Flow Control Performance Standard.

The project applied the Western Washington Hydrology Model (WWHM) iteratively to prove compliance using increasing bioretention and detention vault sizing. The WWHM output is included as Appendix D. Using a Predeveloped Forested Condition for a footprint equal to the area of disturbance along with the proposed stormwater BMPs, the input, output, and results of WWHM are summarized as follows:

### PREDEVELOPED LAND USE

Pervious Land Use	acre
C, Forest, Flat	0.49

Impervious Land Use acre	
ROOF TOPS FLAT	0.02 (existing shed structure)

### MITIGATED LAND USE TO DETENTION VAULT

Pervious Land Use	acre
A B, Pasture, Flat	0.17

Impervious Land Use acre	
ROOF TOPS FLAT	0.18
DRIVEWAYS FLAT	0.05
SIDEWALKS FLAT	0.04

### MITIGATED LAND USE BYPASS

Pervious Land Use	acre
A B, Pasture, Flat	0.07

### DETENTION VAULT PARAMETERS

Width:	7 ft.
Length:	110 ft.

Depth: 7 ft.  
Discharge Structure  
 Riser Height: 6.5 ft.  
 Riser Diameter: 18 in.

Orifice 1 Diameter: 0.25 in. Elevation: 0 ft.  
 Orifice 2 Diameter: 0.125 in. Elevation: 2 ft.  
 Orifice 3 Diameter: 0.125 in. Elevation: 3 ft.

Return Period	100% Predeveloped Flow (cfs)	50% of Predeveloped Flow (cfs)	Mitigated Flow (cfs)	Compliant?
2-Year	0.019	0.010	0.005	Y
50-Year	0.051	-	0.043	Y

## 2.8 MR8: WETLANDS PROTECTION

The project conveys stormwater into the existing public storm drain main in 79th Avenue SE, which outlets downstream into a series of open watercourses prior to outlet into Lake Washington. The drainage pathway is continuously downhill and does not impact any mapped wetlands.

## 2.9 MR9: OPERATIONS AND MAINTENANCE

The project's stormwater systems that require regular maintenance include the oil / water separator and the detention tank (the stormwater pump system is not actually providing Flow Control, and therefore is not required to be included in the Operations and Maintenance requirements).

Potential Defects and Maintenance are included in Appendix E for the oil / water separator and for the detention vault.

## 3. CONVEYANCE SYSTEM ANALYSIS:

In accordance with the City of Mercer Island's Pre-Application meeting guidance, the project is required to convey stormwater to the existing shallow 8" storm drain main

located in 79<sup>th</sup> Avenue SE. The project has no ability to install storm drainage onsite in a manner to gravity flow to the existing main, so a pump system is proposed to elevate discharge just before entering the public right of way through a service drain connection to the public main.

Proposed storm drainage piping is designed with a minimum slope of 1.00% but due to site topography and available locations for bioretention, cannot be sloped at the standard 2.00% and accommodate the topography by gravity flow.

From the Rational Method:

$$Q_{25\text{-Year}} = (C)(i)(A)$$

Where:

- Rainfall intensity (i) can be derived from King County's Surface Water Design Manual isopluvial maps, Section 3.2. for a 25-year, 24-hour occurrence storm event to be a maximum of **3.40 in/hr**.
- Area (A) represents the largest tributary basin to any pipe. The largest collection system is the pipe network carrying flow along the southeast and south downspouts, which deliver the flow into the south bioretention planter and further downstream into the large underground detention vault. That pipe system conveys a total roof area = **3,250 sf (0.075 ac)**
- Runoff coefficient (C) for the scenario is based on the tributary areas, and since the roof flow is the only contributing area the coefficient of **0.90** is appropriate.

The maximum site runoff within any pipe is calculated from Rational Method to be:

$$Q_{25\text{-Year}} = (C)(i)(A)$$

$$Q_{25\text{-Year}} = (0.90)(3.40)(0.075)$$

$$Q_{25\text{-Year}} = 0.23 \text{ cfs}$$

Using Manning's Equation:

- A 4" diameter plastic solid-wall pipe, sloped at 1.00% and flowing 75% full (25% clogged) has capacity to convey **0.23 cfs**.

Therefore, the proposed drainage system pipe sizing is considered to be feasible and appropriate.

APPENDIX A: DOE Flowchart; Requirements for New Dev

**Figure I-3.1: Flow Chart for Determining Requirements for New Development**

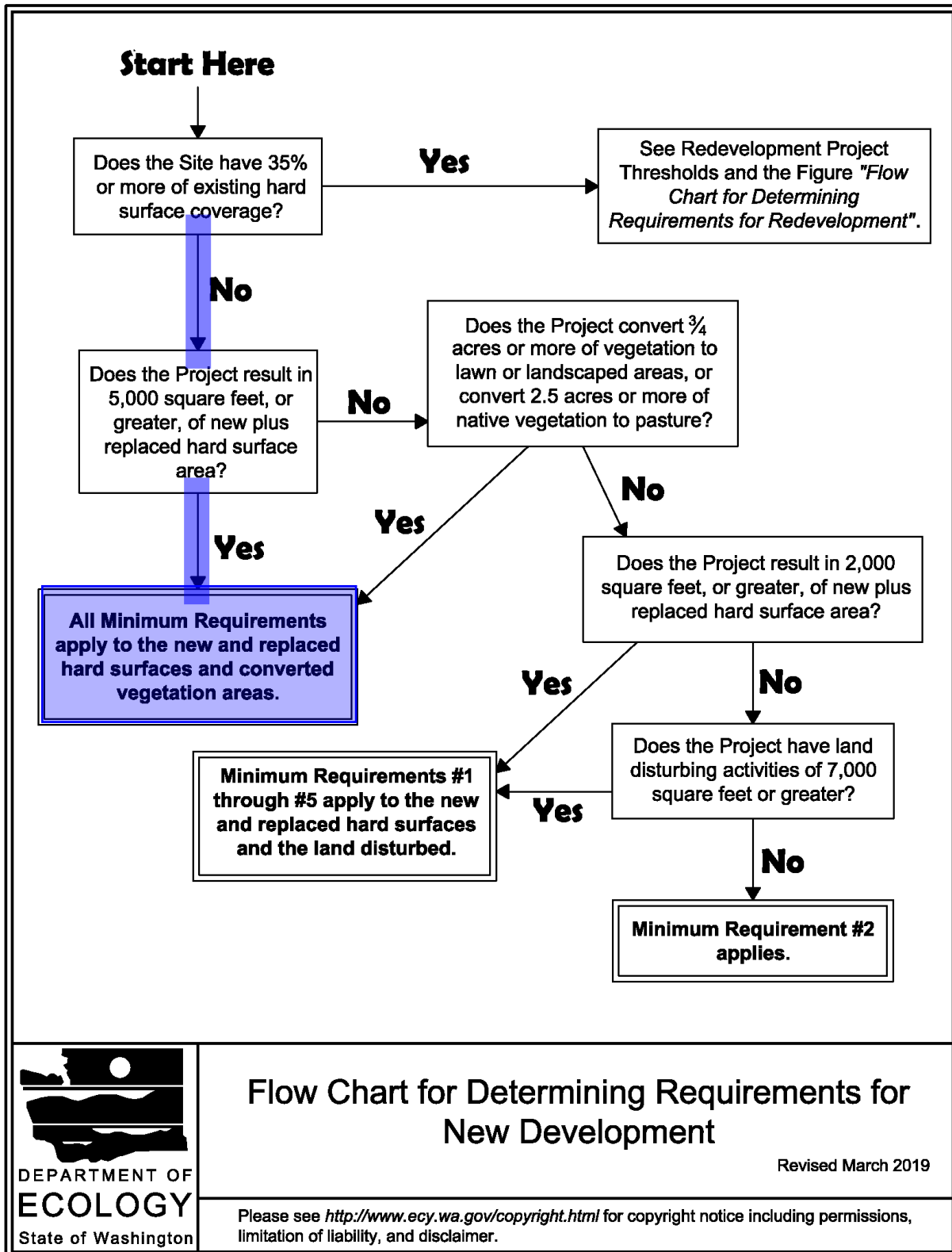

## Flow Chart for Determining Requirements for New Development

Revised March 2019

Please see <http://www.ecy.wa.gov/copyright.html> for copyright notice including permissions, limitation of liability, and disclaimer.

APPENDIX B: Infiltration Feasibility Map

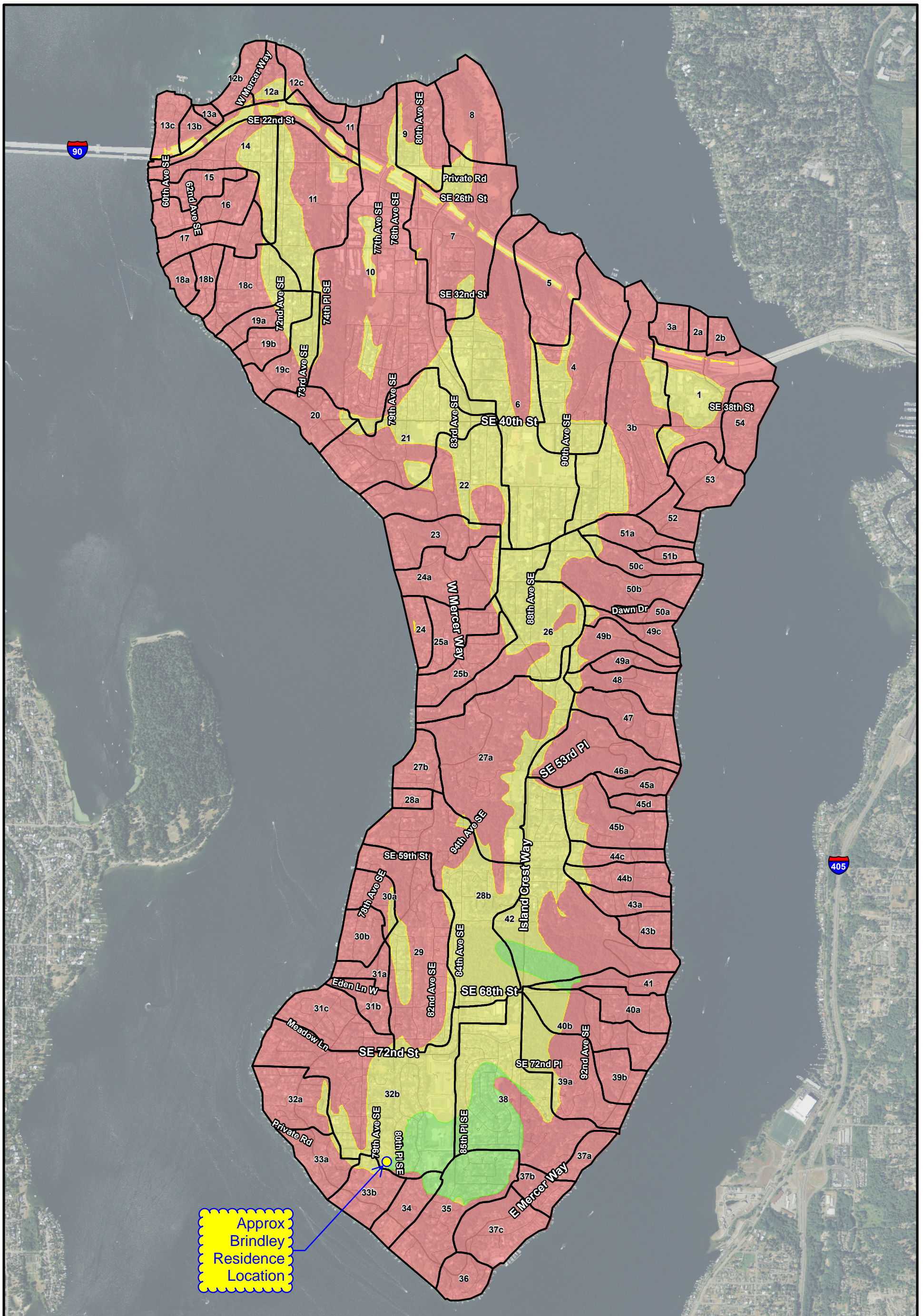

**Legend**

- Infiltrating LID facilities may be feasible, and soil has high infiltration potential
- Infiltrating LID facilities may be feasible, and soil has moderate infiltration potential
- Infiltrating LID facilities are not permitted
- Storm drainage basin

\* Map is intended to be used for planning purposes only. Site-specific analysis is required prior to design and construction of LID facilities.

**Figure 3. Low impact development infiltration feasibility on Mercer Island.**

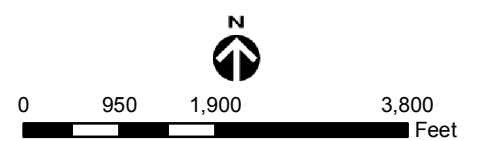

Aerial photography: USDA (2009)  
 K:\Projects\10-04816-000\Project\lid\_feasibility-report-11x17.mxd



## APPENDIX C: WWHM Output

**WWHM2012**  
**PROJECT REPORT**

## General Model Information

Project Name: 79th Ave SW, Mercer Island  
Site Name: 79th Ave SW  
Site Address: 79th Ave SW  
City: Mercer Island  
Report Date: 7/25/2022  
Gage: Seatac  
Data Start: 1948/10/01  
Data End: 2009/09/30  
Timestep: 15 Minute  
Precip Scale: 1.000  
Version Date: 2019/09/13  
Version: 4.2.17

## POC Thresholds

---

Low Flow Threshold for POC1: 8 Percent of the 2 Year  
High Flow Threshold for POC1: 50 Year

---

*Landuse Basin Data*  
*Predeveloped Land Use*

**Existing Condition**

Bypass:	No
GroundWater:	No
Pervious Land Use C, Forest, Flat	acre 0.49
Pervious Total	0.49
Impervious Land Use ROOF TOPS FLAT	acre 0.02
Impervious Total	0.02
Basin Total	0.51

Element Flows To:  
Surface                      Interflow                      Groundwater

DRAFT

## Mitigated Land Use

### Roof and Dwy

Bypass: No

GroundWater: No

Pervious Land Use acre  
A B, Pasture, Flat 0.17

Pervious Total 0.17

Impervious Land Use acre  
ROOF TOPS FLAT 0.18  
DRIVEWAYS FLAT 0.05  
SIDEWALKS FLAT 0.04

Impervious Total 0.27

Basin Total 0.44

### Element Flows To:

Surface	Interflow	Groundwater
Detention Vault	Detention Vault	

DRAFT

## Amended Soil Areas

Bypass:	Yes
GroundWater:	No
Pervious Land Use A B, Pasture, Flat	acre 0.07
Pervious Total	0.07
Impervious Land Use	acre
Impervious Total	0
Basin Total	0.07

Element Flows To:		
Surface	Interflow	Groundwater

DRAFT

*Routing Elements*  
*Predeveloped Routing*

DRAFT

## Mitigated Routing

### Detention Vault

Width: 7 ft.  
Length: 110 ft.  
Depth: 7 ft.  
Discharge Structure  
Riser Height: 6.5 ft.  
Riser Diameter: 8 in.  
Orifice 1 Diameter: 0.25 in. Elevation:0 ft.  
Orifice 2 Diameter: 0.125 in. Elevation:2 ft.  
Orifice 3 Diameter: 0.125 in. Elevation:3 ft.  
Element Flows To:  
Outlet 1                      Outlet 2

Vault Hydraulic Table

Stage(feet)	Area(ac.)	Volume(ac-ft.)	Discharge(cfs)	Infilt(cfs)
0.0000	0.017	0.000	0.000	0.000
0.0778	0.017	0.001	0.000	0.000
0.1556	0.017	0.002	0.000	0.000
0.2333	0.017	0.004	0.000	0.000
0.3111	0.017	0.005	0.000	0.000
0.3889	0.017	0.006	0.001	0.000
0.4667	0.017	0.008	0.001	0.000
0.5444	0.017	0.009	0.001	0.000
0.6222	0.017	0.011	0.001	0.000
0.7000	0.017	0.012	0.001	0.000
0.7778	0.017	0.013	0.001	0.000
0.8556	0.017	0.015	0.001	0.000
0.9333	0.017	0.016	0.001	0.000
1.0111	0.017	0.017	0.001	0.000
1.0889	0.017	0.019	0.001	0.000
1.1667	0.017	0.020	0.001	0.000
1.2444	0.017	0.022	0.001	0.000
1.3222	0.017	0.023	0.002	0.000
1.4000	0.017	0.024	0.002	0.000
1.4778	0.017	0.026	0.002	0.000
1.5556	0.017	0.027	0.002	0.000
1.6333	0.017	0.028	0.002	0.000
1.7111	0.017	0.030	0.002	0.000
1.7889	0.017	0.031	0.002	0.000
1.8667	0.017	0.033	0.002	0.000
1.9444	0.017	0.034	0.002	0.000
2.0222	0.017	0.035	0.002	0.000
2.1000	0.017	0.037	0.002	0.000
2.1778	0.017	0.038	0.002	0.000
2.2556	0.017	0.039	0.002	0.000
2.3333	0.017	0.041	0.002	0.000
2.4111	0.017	0.042	0.002	0.000
2.4889	0.017	0.044	0.003	0.000
2.5667	0.017	0.045	0.003	0.000
2.6444	0.017	0.046	0.003	0.000
2.7222	0.017	0.048	0.003	0.000
2.8000	0.017	0.049	0.003	0.000
2.8778	0.017	0.050	0.003	0.000



2.9556	0.017	0.052	0.003	0.000
3.0333	0.017	0.053	0.003	0.000
3.1111	0.017	0.055	0.003	0.000
3.1889	0.017	0.056	0.003	0.000
3.2667	0.017	0.057	0.003	0.000
3.3444	0.017	0.059	0.003	0.000
3.4222	0.017	0.060	0.003	0.000
3.5000	0.017	0.061	0.004	0.000
3.5778	0.017	0.063	0.004	0.000
3.6556	0.017	0.064	0.004	0.000
3.7333	0.017	0.066	0.004	0.000
3.8111	0.017	0.067	0.004	0.000
3.8889	0.017	0.068	0.004	0.000
3.9667	0.017	0.070	0.004	0.000
4.0444	0.017	0.071	0.004	0.000
4.1222	0.017	0.072	0.004	0.000
4.2000	0.017	0.074	0.004	0.000
4.2778	0.017	0.075	0.004	0.000
4.3556	0.017	0.077	0.004	0.000
4.4333	0.017	0.078	0.004	0.000
4.5111	0.017	0.079	0.004	0.000
4.5889	0.017	0.081	0.004	0.000
4.6667	0.017	0.082	0.004	0.000
4.7444	0.017	0.083	0.005	0.000
4.8222	0.017	0.085	0.005	0.000
4.9000	0.017	0.086	0.005	0.000
4.9778	0.017	0.088	0.005	0.000
5.0556	0.017	0.089	0.005	0.000
5.1333	0.017	0.090	0.005	0.000
5.2111	0.017	0.092	0.005	0.000
5.2889	0.017	0.093	0.005	0.000
5.3667	0.017	0.094	0.005	0.000
5.4444	0.017	0.096	0.005	0.000
5.5222	0.017	0.097	0.005	0.000
5.6000	0.017	0.099	0.005	0.000
5.6778	0.017	0.100	0.005	0.000
5.7556	0.017	0.101	0.005	0.000
5.8333	0.017	0.103	0.005	0.000
5.9111	0.017	0.104	0.005	0.000
5.9889	0.017	0.105	0.005	0.000
6.0667	0.017	0.107	0.005	0.000
6.1444	0.017	0.108	0.005	0.000
6.2222	0.017	0.110	0.005	0.000
6.3000	0.017	0.111	0.005	0.000
6.3778	0.017	0.112	0.005	0.000
6.4556	0.017	0.114	0.006	0.000
6.5333	0.017	0.115	0.049	0.000
6.6111	0.017	0.116	0.261	0.000
6.6889	0.017	0.118	0.519	0.000
6.7667	0.017	0.119	0.717	0.000
6.8444	0.017	0.121	0.827	0.000
6.9222	0.017	0.122	0.915	0.000
7.0000	0.017	0.123	0.996	0.000
7.0778	0.017	0.125	1.070	0.000
7.1556	0.000	0.000	1.139	0.000

DRAFT

# Analysis Results

## POC 1

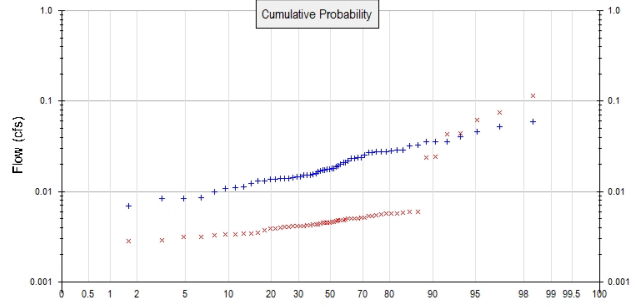
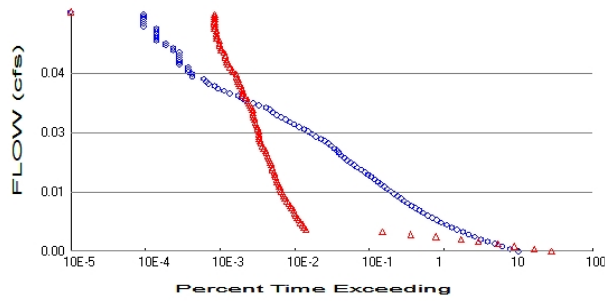

+ Predeveloped x Mitigated

### Predeveloped Landuse Totals for POC #1

Total Pervious Area: 0.49  
 Total Impervious Area: 0.02

### Mitigated Landuse Totals for POC #1

Total Pervious Area: 0.24  
 Total Impervious Area: 0.27

Flow Frequency Method: Log Pearson Type III 17B

### Flow Frequency Return Periods for Predeveloped. POC #1

Return Period	Flow(cfs)
2 year	0.018597
5 year	0.027997
10 year	0.034831
25 year	0.044119
50 year	0.051495
100 year	0.059255

### Flow Frequency Return Periods for Mitigated. POC #1

Return Period	Flow(cfs)
2 year	0.005136
5 year	0.010826
10 year	0.017066
25 year	0.029199
50 year	0.042531
100 year	0.060852

## Annual Peaks

### Annual Peaks for Predeveloped and Mitigated. POC #1

Year	Predeveloped	Mitigated
1949	0.024	0.004
1950	0.025	0.005
1951	0.036	0.044
1952	0.014	0.003
1953	0.011	0.005
1954	0.014	0.004
1955	0.023	0.004
1956	0.021	0.005
1957	0.020	0.004
1958	0.017	0.005

1959	0.014	0.004
1960	0.028	0.006
1961	0.016	0.005
1962	0.010	0.003
1963	0.014	0.005
1964	0.018	0.005
1965	0.015	0.005
1966	0.013	0.004
1967	0.028	0.005
1968	0.018	0.004
1969	0.017	0.004
1970	0.015	0.004
1971	0.018	0.005
1972	0.027	0.006
1973	0.014	0.005
1974	0.017	0.004
1975	0.024	0.004
1976	0.017	0.004
1977	0.007	0.003
1978	0.014	0.005
1979	0.011	0.003
1980	0.032	0.024
1981	0.014	0.004
1982	0.028	0.006
1983	0.019	0.004
1984	0.013	0.003
1985	0.008	0.003
1986	0.029	0.005
1987	0.028	0.006
1988	0.011	0.004
1989	0.008	0.003
1990	0.060	0.006
1991	0.036	0.006
1992	0.016	0.005
1993	0.014	0.003
1994	0.007	0.003
1995	0.019	0.005
1996	0.040	0.044
1997	0.033	0.076
1998	0.012	0.003
1999	0.036	0.024
2000	0.015	0.005
2001	0.009	0.002
2002	0.018	0.005
2003	0.023	0.004
2004	0.027	0.062
2005	0.021	0.004
2006	0.022	0.005
2007	0.046	0.115
2008	0.052	0.006
2009	0.029	0.005

DRAFT

### Ranked Annual Peaks

Ranked Annual Peaks for Predeveloped and Mitigated. POC #1

Rank	Predeveloped	Mitigated
1	0.0598	0.1149
2	0.0525	0.0757
3	0.0457	0.0623

4	0.0404	0.0437
5	0.0358	0.0436
6	0.0356	0.0243
7	0.0356	0.0237
8	0.0327	0.0060
9	0.0317	0.0060
10	0.0291	0.0059
11	0.0289	0.0057
12	0.0279	0.0057
13	0.0278	0.0057
14	0.0278	0.0056
15	0.0277	0.0055
16	0.0273	0.0054
17	0.0271	0.0053
18	0.0252	0.0052
19	0.0238	0.0052
20	0.0236	0.0051
21	0.0233	0.0050
22	0.0231	0.0050
23	0.0216	0.0050
24	0.0209	0.0050
25	0.0208	0.0048
26	0.0199	0.0048
27	0.0192	0.0048
28	0.0188	0.0047
29	0.0180	0.0046
30	0.0179	0.0046
31	0.0176	0.0045
32	0.0175	0.0045
33	0.0172	0.0045
34	0.0171	0.0045
35	0.0170	0.0044
36	0.0165	0.0043
37	0.0158	0.0043
38	0.0156	0.0043
39	0.0153	0.0043
40	0.0153	0.0042
41	0.0152	0.0042
42	0.0145	0.0041
43	0.0144	0.0041
44	0.0141	0.0041
45	0.0140	0.0041
46	0.0140	0.0041
47	0.0138	0.0040
48	0.0137	0.0039
49	0.0137	0.0039
50	0.0132	0.0037
51	0.0131	0.0035
52	0.0123	0.0034
53	0.0113	0.0034
54	0.0109	0.0034
55	0.0109	0.0034
56	0.0100	0.0032
57	0.0086	0.0032
58	0.0083	0.0031
59	0.0083	0.0029
60	0.0069	0.0029
61	0.0066	0.0024

DRAFT

DRAFT

## Duration Flows

Flow(cfs)	Predev	Mit	Percentage	Pass/Fail
0.0015	214744	590973	275	Fail
0.0020	164565	345001	209	Fail
0.0025	128996	187644	145	Fail
0.0030	102730	112954	109	Fail
0.0035	82689	61557	74	Pass
0.0040	67204	36254	53	Pass
0.0045	55290	16747	30	Pass
0.0050	45900	7668	16	Pass
0.0055	38307	3191	8	Pass
0.0060	32062	303	0	Pass
0.0065	27121	284	1	Pass
0.0070	23079	275	1	Pass
0.0075	19708	257	1	Pass
0.0081	16914	244	1	Pass
0.0086	14743	233	1	Pass
0.0091	12906	220	1	Pass
0.0096	11340	214	1	Pass
0.0101	10029	206	2	Pass
0.0106	8891	194	2	Pass
0.0111	7886	186	2	Pass
0.0116	7007	177	2	Pass
0.0121	6263	170	2	Pass
0.0126	5634	158	2	Pass
0.0131	5073	154	3	Pass
0.0136	4560	149	3	Pass
0.0141	4119	143	3	Pass
0.0146	3720	135	3	Pass
0.0151	3377	134	3	Pass
0.0156	3046	130	4	Pass
0.0161	2772	123	4	Pass
0.0166	2511	122	4	Pass
0.0171	2263	118	5	Pass
0.0177	2041	115	5	Pass
0.0182	1858	113	6	Pass
0.0187	1660	109	6	Pass
0.0192	1487	107	7	Pass
0.0197	1339	103	7	Pass
0.0202	1205	101	8	Pass
0.0207	1083	99	9	Pass
0.0212	989	96	9	Pass
0.0217	910	92	10	Pass
0.0222	836	89	10	Pass
0.0227	782	87	11	Pass
0.0232	722	82	11	Pass
0.0237	663	79	11	Pass
0.0242	593	75	12	Pass
0.0247	535	73	13	Pass
0.0252	477	72	15	Pass
0.0257	413	71	17	Pass
0.0262	368	71	19	Pass
0.0267	324	71	21	Pass
0.0272	286	68	23	Pass
0.0278	246	68	27	Pass
0.0283	210	65	30	Pass

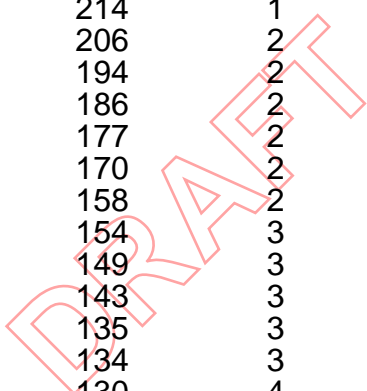

0.0288	185	63	34	Pass
0.0293	162	62	38	Pass
0.0298	140	60	42	Pass
0.0303	121	59	48	Pass
0.0308	109	59	54	Pass
0.0313	100	58	58	Pass
0.0318	88	56	63	Pass
0.0323	71	54	76	Pass
0.0328	59	52	88	Pass
0.0333	47	50	106	Pass
0.0338	41	47	114	Fail
0.0343	37	43	116	Fail
0.0348	29	43	148	Fail
0.0353	24	43	179	Fail
0.0358	20	42	209	Fail
0.0363	18	40	222	Fail
0.0368	15	38	253	Fail
0.0374	14	37	264	Fail
0.0379	13	37	284	Fail
0.0384	9	35	388	Fail
0.0389	9	35	388	Fail
0.0394	8	32	400	Fail
0.0399	8	31	387	Fail
0.0404	8	29	362	Fail
0.0409	6	27	450	Fail
0.0414	6	26	433	Fail
0.0419	6	26	433	Fail
0.0424	6	25	416	Fail
0.0429	6	25	416	Fail
0.0434	6	24	400	Fail
0.0439	5	22	440	Fail
0.0444	5	22	440	Fail
0.0449	4	21	525	Fail
0.0454	4	21	525	Fail
0.0459	3	21	700	Fail
0.0464	3	19	633	Fail
0.0469	3	19	633	Fail
0.0475	3	19	633	Fail
0.0480	3	19	633	Fail
0.0485	3	18	600	Fail
0.0490	2	18	900	Fail
0.0495	2	18	900	Fail
0.0500	2	18	900	Fail
0.0505	2	18	900	Fail
0.0510	2	18	900	Fail
0.0515	2	18	900	Fail

The development has an increase in flow durations from 1/2 Predeveloped 2 year flow to the 2 year flow or more than a 10% increase from the 2 year to the 50 year flow.

## Water Quality

Water Quality BMP Flow and Volume for POC #1

On-line facility volume: 0 acre-feet

On-line facility target flow: 0 cfs.

Adjusted for 15 min: 0 cfs.

Off-line facility target flow: 0 cfs.

Adjusted for 15 min: 0 cfs.

DRAFT



# LID Report

LID Technique	Used for Treatment ?	Total Volume Needs Treatment (ac-ft)	Volume Through Facility (ac-ft)	Infiltration Volume (ac-ft)	Cumulative Volume Infiltration Credit	Percent Volume Infiltrated	Water Quality	Percent Water Quality Treated	Comment
Detention Vault POC	<input type="checkbox"/>	38.65			<input type="checkbox"/>	0.00			
Total Volume Infiltrated		38.65	0.00	0.00		0.00	0.00	0%	No Treat. Credit
Compliance with LID Standard 8% of 2-yr to 50% of 2-yr									Duration Analysis Result = Failed

DRAFT

## *Model Default Modifications*

Total of 0 changes have been made.

### *PERLND Changes*

No PERLND changes have been made.

### *IMPLND Changes*

No IMPLND changes have been made.

DRAFT

*Appendix*  
*Predeveloped Schematic*



Existing  
Condition  
0.51ac

Mitigated Schematic

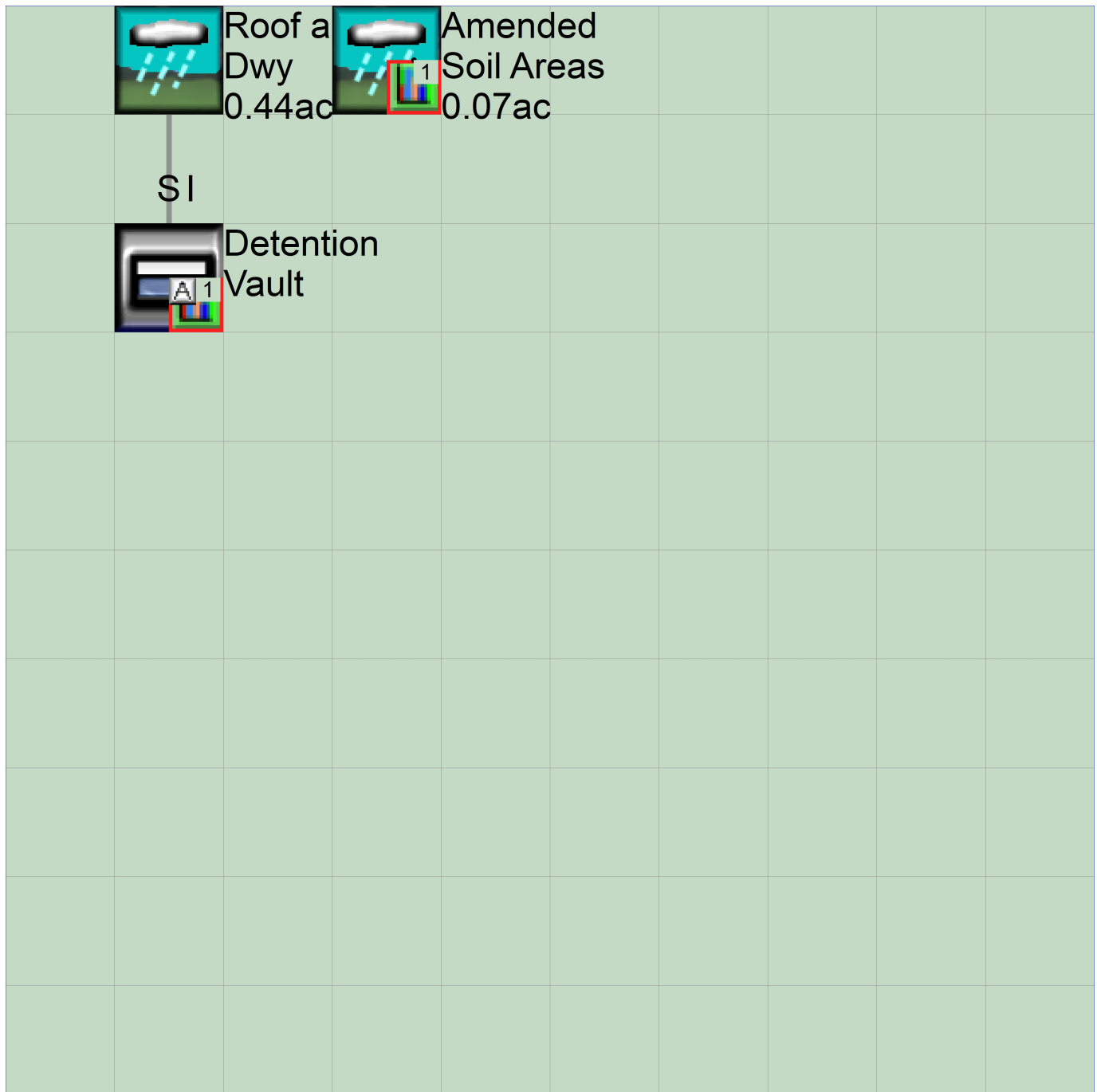

# Predeveloped UCI File

RUN

## GLOBAL

```
WVHM4 model simulation
START      1948 10 01      END      2009 09 30
RUN INTERP OUTPUT LEVEL   3      0
RESUME     0 RUN         1
UNIT SYSTEM 1
```

END GLOBAL

## FILES

```
<File> <Un#> <-----File Name----->***
<-ID->                                     ***
WDM      26      79th Ave SW, Mercer Island.wdm
MESSU    25      Pre79th Ave SW, Mercer Island.MES
          27      Pre79th Ave SW, Mercer Island.L61
          28      Pre79th Ave SW, Mercer Island.L62
          30      POC79th Ave SW, Mercer Island1.dat
```

END FILES

## OPN SEQUENCE

```
INGRP          INDELT 00:15
  PERLND       10
  IMPLND        4
  COPY         501
  DISPLY        1
```

END INGRP

END OPN SEQUENCE

## DISPLY

DISPLY-INFO1

```
# - #<-----Title----->***TRAN PIVL DIG1 FIL1  PYR DIG2 FIL2 YRND
1      Existing Condition      MAX          1    2    30    9
```

END DISPLY-INFO1

END DISPLY

## COPY

TIMESERIES

```
# - # NPT NMN ***
1      1    1
501    1    1
```

END TIMESERIES

END COPY

## GENER

OPCODE

```
# # OPCD ***
```

END OPCODE

PARM

```
# # K ***
```

END PARM

END GENER

## PERLND

GEN-INFO

```
<PLS ><-----Name----->NBLKS Unit-systems Printer ***
# - # User t-series Engl Metr ***
          in out ***
```

```
10      C, Forest, Flat      1    1    1    1    27    0
```

END GEN-INFO

\*\*\* Section PWATER\*\*\*

## ACTIVITY

```
<PLS > ***** Active Sections *****
```

```
# - # ATMP SNOW PWAT SED PST PWG PQAL MSTL PEST NITR PHOS TRAC ***
10      0    0    1    0    0    0    0    0    0    0    0    0
```

END ACTIVITY

## PRINT-INFO

```
<PLS > ***** Print-flags ***** PIVL PYR
# - # ATMP SNOW PWAT SED PST PWG PQAL MSTL PEST NITR PHOS TRAC *****
10      0    0    4    0    0    0    0    0    0    0    0    0    1    9
```

END PRINT-INFO

```

PWAT-PARM1
  <PLS > PWATER variable monthly parameter value flags ***
  # - # CSNO RTOP UZFG VCS VUZ VNN VIFW VIRC VLE INFC HWT ***
  10 0 0 0 0 0 0 0 0 0 0 0
END PWAT-PARM1

PWAT-PARM2
  <PLS > PWATER input info: Part 2 ***
  # - # ***FOREST LZSN INFILT LSUR SLSUR KVARY AGWRC
  10 0 4.5 0.08 400 0.05 0.5 0.996
END PWAT-PARM2

PWAT-PARM3
  <PLS > PWATER input info: Part 3 ***
  # - # ***PETMAX PETMIN INFEXP INFILD DEEPFR BASETP AGWETP
  10 0 0 2 2 0 0 0
END PWAT-PARM3

PWAT-PARM4
  <PLS > PWATER input info: Part 4 ***
  # - # CEPSC UZSN NSUR INTFW IRC LZETP ***
  10 0.2 0.5 0.35 6 0.5 0.7
END PWAT-PARM4

PWAT-STATE1
  <PLS > *** Initial conditions at start of simulation
  ran from 1990 to end of 1992 (pat 1-11-95) RUN 21 ***
  # - # *** CEPS SURS UZS IFWS LZS AGWS GWVS
  10 0 0 0 0 2.5 1 0
END PWAT-STATE1

END PERLND

IMPLND
GEN-INFO
  <PLS ><-----Name-----> Unit-systems Printer ***
  # - # User t-series Engl Metr ***
  in out ***
  4 ROOF TOPS/FLAT 1 1 1 27 0
END GEN-INFO
*** Section IWATER***

ACTIVITY
  <PLS > ***** Active Sections *****
  # - # ATMP SNOW IWAT SLD IWG IQAL ***
  4 0 0 1 0 0 0
END ACTIVITY

PRINT-INFO
  <ILS > ***** Print-flags ***** PIVL PYR
  # - # ATMP SNOW IWAT SLD IWG IQAL *****
  4 0 0 4 0 0 0 1 9
END PRINT-INFO

IWAT-PARM1
  <PLS > IWATER variable monthly parameter value flags ***
  # - # CSNO RTOP VRS VNN RTLI ***
  4 0 0 0 0 0
END IWAT-PARM1

IWAT-PARM2
  <PLS > IWATER input info: Part 2 ***
  # - # *** LSUR SLSUR NSUR RETSC
  4 400 0.01 0.1 0.1
END IWAT-PARM2

IWAT-PARM3
  <PLS > IWATER input info: Part 3 ***
  # - # ***PETMAX PETMIN
  4 0 0

```



END SPEC-ACTIONS  
FTABLES  
END FTABLES

EXT SOURCES

<-Volume->	<Member>	SsysSgap<--Mult-->	Tran	<-Target	vols>	<-Grp>	<-Member->	***	
<Name>	#	<Name>	#	tem strg<-factor->	strg	<Name>	#	#	***
WDM	2	PREC	ENGL	1	PERLND	1 999	EXTNL	PREC	***
WDM	2	PREC	ENGL	1	IMPLND	1 999	EXTNL	PREC	***
WDM	1	EVAP	ENGL	0.76	PERLND	1 999	EXTNL	PETINP	***
WDM	1	EVAP	ENGL	0.76	IMPLND	1 999	EXTNL	PETINP	***

END EXT SOURCES

EXT TARGETS

<-Volume->	<-Grp>	<-Member->	<--Mult-->	Tran	<-Volume->	<Member>	Tsys	Tgap	Amd	***
<Name>	#	<Name>	#	#<-factor->	strg	<Name>	#	<Name>	tem strg	strg***
COPY	501	OUTPUT	MEAN	1 1	48.4	WDM	501	FLOW	ENGL	REPL

END EXT TARGETS

MASS-LINK

<Volume>	<-Grp>	<-Member->	<--Mult-->	<Target>	<-Grp>	<-Member->	***		
<Name>	#	<Name>	#	#<-factor->	<Name>	<Name>	#	#	***
MASS-LINK			12						
PERLND	PWATER	SURO		0.083333	COPY	INPUT	MEAN		
END MASS-LINK			12						
MASS-LINK			13						
PERLND	PWATER	IFWO		0.083333	COPY	INPUT	MEAN		
END MASS-LINK			13						
MASS-LINK			15						
IMPLND	IWATER	SURO		0.083333	COPY	INPUT	MEAN		
END MASS-LINK			15						

END MASS-LINK

END RUN

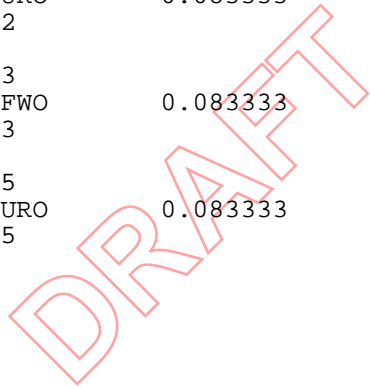



# Mitigated UCI File

RUN

GLOBAL

```
WVHM4 model simulation
START      1948 10 01      END      2009 09 30
RUN INTERP OUTPUT LEVEL   3      0
RESUME     0 RUN         1
UNIT SYSTEM 1
```

FILES

```
<File> <Un#> <-----File Name----->***
<-ID->                                     ***
WDM      26      79th Ave SW, Mercer Island.wdm
MESSU    25      Mit79th Ave SW, Mercer Island.MES
          27      Mit79th Ave SW, Mercer Island.L61
          28      Mit79th Ave SW, Mercer Island.L62
          30      POC79th Ave SW, Mercer Island1.dat
```

END FILES

OPN SEQUENCE

INGRP INDELT 00:15

```
PERLND 4
IMPLND 4
IMPLND 5
IMPLND 8
RCHRES 1
COPY    1
COPY    501
COPY    601
DISPLY 1
```

END INGRP

END OPN SEQUENCE

DISPLY

DISPLY-INFO1

```
# - #<-----Title----->***TRAN PIVL DIG1 FIL1 PYR DIG2 FIL2 YRND
1 Detention Vault MAX 1 2 30 9
```

END DISPLY-INFO1

END DISPLY

COPY

TIMESERIES

```
# - # NPT NMN ***
1 1 1
501 1 1
601 1 1
```

END TIMESERIES

END COPY

GENER

OPCODE

```
# # OPCD ***
```

END OPCODE

PARM

```
# # K ***
```

END PARM

END GENER

PERLND

GEN-INFO

```
<PLS ><-----Name----->NBLKS Unit-systems Printer ***
# - # User t-series Engl Metr ***
in out ***
```

```
4 A/B, Pasture, Flat 1 1 1 1 27 0
```

END GEN-INFO

\*\*\* Section PWATER\*\*\*

ACTIVITY

```
<PLS > ***** Active Sections *****
# - # ATMP SNOW PWAT SED PST PWG PQAL MSTL PEST NITR PHOS TRAC ***
4 0 0 1 0 0 0 0 0 0 0 0 0
```

END ACTIVITY

```

PRINT-INFO
<PLS > ***** Print-flags ***** PIVL  PYR
# - # ATMP SNOW PWAT  SED  PST  PWG  PQAL MSTL PEST NITR PHOS TRAC  *****
4      0      0      4      0      0      0      0      0      0      0      0      0      0      1      9
END PRINT-INFO

```

```

PWAT-PARM1
<PLS >  PWATER variable monthly parameter value flags  ***
# - # CSNO RTOP UZFG  VCS  VUZ  VNN VIFW VIRC  VLE INFC  HWT  ***
4      0      0      0      0      0      0      0      0      0      0      0
END PWAT-PARM1

```

```

PWAT-PARM2
<PLS >      PWATER input info: Part 2          ***
# - # ***FOREST      LZSN      INFILT      LSUR      SLSUR      KVARY      AGWRC
4      0      5      1.5      400      0.05      0.3      0.996
END PWAT-PARM2

```

```

PWAT-PARM3
<PLS >      PWATER input info: Part 3          ***
# - # ***PETMAX      PETMIN      INFEXP      INFILD      DEEPFR      BASETP      AGWETP
4      0      0      2      2      0      0      0
END PWAT-PARM3

```

```

PWAT-PARM4
<PLS >      PWATER input info: Part 4          ***
# - #      CEPSC      UZSN      NSUR      INTFW      IRC      LZETP  ***
4      0.15      0.5      0.3      0      0.7      0.4
END PWAT-PARM4

```

```

PWAT-STATE1
<PLS > *** Initial conditions at start of simulation
ran from 1990 to end of 1992 (pat 1-11-95) RUN 21 ***
# - # *** CEPS      SURS      UZS      IFWS      LZS      AGWS      GWVS
4      0      0      0      0      3      1      0
END PWAT-STATE1

```

END PERLND

IMPLND

```

GEN-INFO
<PLS ><-----Name----->  Unit-systems  Printer  ***
# - #      User  t-series  Engl  Metr  ***
      in  out      ***
4      ROOF TOPS/FLAT      1      1      1      27      0
5      DRIVEWAYS/FLAT      1      1      1      27      0
8      SIDEWALKS/FLAT      1      1      1      27      0
END GEN-INFO
*** Section IWATER***

```

```

ACTIVITY
<PLS > ***** Active Sections *****
# - # ATMP SNOW IWAT  SLD  IWG IQAL  ***
4      0      0      1      0      0      0
5      0      0      1      0      0      0
8      0      0      1      0      0      0
END ACTIVITY

```

```

PRINT-INFO
<ILS > ***** Print-flags ***** PIVL  PYR
# - # ATMP SNOW IWAT  SLD  IWG IQAL  *****
4      0      0      4      0      0      0      1      9
5      0      0      4      0      0      0      1      9
8      0      0      4      0      0      0      1      9
END PRINT-INFO

```

```

IWAT-PARM1
<PLS >  IWATER variable monthly parameter value flags  ***
# - # CSNO RTOP  VRS  VNN RTLI      ***
4      0      0      0      0      0

```

5 0 0 0 0 0  
8 0 0 0 0 0  
END IWAT-PARM1

IWAT-PARM2  
<PLS > IWATER input info: Part 2 \*\*\*  
# - # \*\*\* LSUR SLSUR NSUR RETSC  
4 400 0.01 0.1 0.1  
5 400 0.01 0.1 0.1  
8 400 0.01 0.1 0.1  
END IWAT-PARM2

IWAT-PARM3  
<PLS > IWATER input info: Part 3 \*\*\*  
# - # \*\*\*PETMAX PETMIN  
4 0 0  
5 0 0  
8 0 0  
END IWAT-PARM3

IWAT-STATE1  
<PLS > \*\*\* Initial conditions at start of simulation  
# - # \*\*\* RETS SURS  
4 0 0  
5 0 0  
8 0 0  
END IWAT-STATE1

END IMPLND

SCHEMATIC  
<-Source-> <-Area--> <-Target-> MBLK \*\*\*  
<Name> # <-factor-> <Name> # Tbl# \*\*\*  
Roof and Dwy\*\*\*  
PERLND 4 0.17 RCHRES 1 2  
PERLND 4 0.17 RCHRES 1 3  
IMPLND 4 0.18 RCHRES 1 5  
IMPLND 5 0.05 RCHRES 1 5  
IMPLND 8 0.04 RCHRES 1 5  
Amended Soil Areas\*\*\*  
PERLND 4 0.07 COPY 501 12  
PERLND 4 0.07 COPY 601 12  
PERLND 4 0.07 COPY 501 13  
PERLND 4 0.07 COPY 601 13  
\*\*\*\*\*Routing\*\*\*\*\*  
PERLND 4 0.17 COPY 1 12  
IMPLND 4 0.18 COPY 1 15  
IMPLND 5 0.05 COPY 1 15  
IMPLND 8 0.04 COPY 1 15  
PERLND 4 0.17 COPY 1 13  
RCHRES 1 1 COPY 501 16  
END SCHEMATIC

NETWORK  
<-Volume-> <-Grp> <-Member-><--Mult-->Tran <-Target vols> <-Grp> <-Member-> \*\*\*  
<Name> # <Name> # #<-factor->strg <Name> # # <Name> # # \*\*\*  
COPY 501 OUTPUT MEAN 1 1 48.4 DISPLY 1 INPUT TIMSER 1

<-Volume-> <-Grp> <-Member-><--Mult-->Tran <-Target vols> <-Grp> <-Member-> \*\*\*  
<Name> # <Name> # #<-factor->strg <Name> # # <Name> # # \*\*\*  
END NETWORK

RCHRES  
GEN-INFO  
RCHRES Name Nexits Unit Systems Printer \*\*\*  
# - #<-----><----> User T-series Engl Metr LKFG \*\*\*  
in out \*\*\*



1.944444	0.017677	0.034371	0.002365
2.022222	0.017677	0.035746	0.002475
2.100000	0.017677	0.037121	0.002592
2.177778	0.017677	0.038496	0.002682
2.255556	0.017677	0.039871	0.002762
2.333333	0.017677	0.041246	0.002836
2.411111	0.017677	0.042621	0.002905
2.488889	0.017677	0.043996	0.002972
2.566667	0.017677	0.045370	0.003036
2.644444	0.017677	0.046745	0.003098
2.722222	0.017677	0.048120	0.003159
2.800000	0.017677	0.049495	0.003217
2.877778	0.017677	0.050870	0.003274
2.955556	0.017677	0.052245	0.003330
3.033333	0.017677	0.053620	0.003462
3.111111	0.017677	0.054994	0.003580
3.188889	0.017677	0.056369	0.003675
3.266667	0.017677	0.057744	0.003762
3.344444	0.017677	0.059119	0.003842
3.422222	0.017677	0.060494	0.003919
3.500000	0.017677	0.061869	0.003992
3.577778	0.017677	0.063244	0.004063
3.655556	0.017677	0.064618	0.004132
3.733333	0.017677	0.065993	0.004198
3.811111	0.017677	0.067368	0.004264
3.888889	0.017677	0.068743	0.004327
3.966667	0.017677	0.070118	0.004389
4.044444	0.017677	0.071493	0.004450
4.122222	0.017677	0.072868	0.004510
4.200000	0.017677	0.074242	0.004569
4.277778	0.017677	0.075617	0.004627
4.355556	0.017677	0.076992	0.004684
4.433333	0.017677	0.078367	0.004740
4.511111	0.017677	0.079742	0.004795
4.588889	0.017677	0.081117	0.004850
4.666667	0.017677	0.082492	0.004904
4.744444	0.017677	0.083866	0.004957
4.822222	0.017677	0.085241	0.005009
4.900000	0.017677	0.086616	0.005061
4.977778	0.017677	0.087991	0.005112
5.055556	0.017677	0.089366	0.005163
5.133333	0.017677	0.090741	0.005213
5.211111	0.017677	0.092116	0.005262
5.288889	0.017677	0.093490	0.005311
5.366667	0.017677	0.094865	0.005359
5.444444	0.017677	0.096240	0.005407
5.522222	0.017677	0.097615	0.005455
5.600000	0.017677	0.098990	0.005502
5.677778	0.017677	0.100365	0.005548
5.755556	0.017677	0.101740	0.005595
5.833333	0.017677	0.103114	0.005640
5.911111	0.017677	0.104489	0.005686
5.988889	0.017677	0.105864	0.005731
6.066667	0.017677	0.107239	0.005775
6.144444	0.017677	0.108614	0.005819
6.222222	0.017677	0.109989	0.005863
6.300000	0.017677	0.111364	0.005907
6.377778	0.017677	0.112738	0.005950
6.455556	0.017677	0.114113	0.005993
6.533333	0.017677	0.115488	0.049031
6.611111	0.017677	0.116863	0.261344
6.688889	0.017677	0.118238	0.519869
6.766667	0.017677	0.119613	0.717432
6.844444	0.017677	0.120988	0.827757
6.922222	0.017677	0.122363	0.915837
7.000000	0.017677	0.123737	0.996117
7.077778	0.017677	0.125112	1.070363

END FTABLE 1

END FTABLES

EXT SOURCES

<-Volume->	<Member>	SsysSgap	<--Mult-->	Tran	<-Target vols>	<-Grp>	<-Member->	***	
<Name>	#	<Name>	#	tem strg	<-factor->	strg	<Name>	# #	***
WDM	2	PREC		ENGL	1		PERLND	1 999	EXTNL PREC
WDM	2	PREC		ENGL	1		IMPLND	1 999	EXTNL PREC
WDM	1	EVAP		ENGL	0.76		PERLND	1 999	EXTNL PETINP
WDM	1	EVAP		ENGL	0.76		IMPLND	1 999	EXTNL PETINP

END EXT SOURCES

EXT TARGETS

<-Volume->	<-Grp>	<-Member->	<--Mult-->	Tran	<-Volume->	<Member>	Tsys	Tgap	Amd	***
<Name>	#	<Name>	#	#<-factor->	strg	<Name>	#	<Name>	tem strg	strg***
RCHRES	1	HYDR	RO	1 1	1	WDM	1012	FLOW	ENGL	REPL
RCHRES	1	HYDR	STAGE	1 1	1	WDM	1013	STAG	ENGL	REPL
COPY	1	OUTPUT	MEAN	1 1	48.4	WDM	701	FLOW	ENGL	REPL
COPY	501	OUTPUT	MEAN	1 1	48.4	WDM	801	FLOW	ENGL	REPL
COPY	601	OUTPUT	MEAN	1 1	48.4	WDM	901	FLOW	ENGL	REPL

END EXT TARGETS

MASS-LINK

<Volume>	<-Grp>	<-Member->	<--Mult-->	<Target>	<-Grp>	<-Member->	***	
<Name>	#	<Name>	#	#<-factor->	<Name>	#	#	***
MASS-LINK			2					
PERLND	PWATER	SURO		0.083333	RCHRES	INFLOW	IVOL	
END MASS-LINK			2					
MASS-LINK			3					
PERLND	PWATER	IFWO		0.083333	RCHRES	INFLOW	IVOL	
END MASS-LINK			3					
MASS-LINK			5					
IMPLND	IWATER	SURO		0.083333	RCHRES	INFLOW	IVOL	
END MASS-LINK			5					
MASS-LINK			12					
PERLND	PWATER	SURO		0.083333	COPY	INPUT	MEAN	
END MASS-LINK			12					
MASS-LINK			13					
PERLND	PWATER	IFWO		0.083333	COPY	INPUT	MEAN	
END MASS-LINK			13					
MASS-LINK			15					
IMPLND	IWATER	SURO		0.083333	COPY	INPUT	MEAN	
END MASS-LINK			15					
MASS-LINK			16					
RCHRES	ROFLOW				COPY	INPUT	MEAN	
END MASS-LINK			16					

END MASS-LINK

END RUN

DRAFT

## Mitigated HSPF Message File

ERROR/WARNING ID: 238 1

The continuity error reported below is greater than 1 part in 1000 and is therefore considered high.

Did you specify any "special actions"? If so, they could account for it.

Relevant data are:

DATE/TIME: 1999/ 9/30 24: 0

RCHRES : 1

RELERR	STORS	STOR	MATIN	MATDIF
-5.473E-03	0.00000	0.0000E+00	0.00000	-1.085E-08

Where:

RELERR is the relative error (ERROR/REFVAL).

ERROR is (STOR-STORS) - MATDIF.

REFVAL is the reference value (STORS+MATIN).

STOR is the storage of material in the processing unit (land-segment or reach/reservoir) at the end of the present interval.

STORS is the storage of material in the pu at the start of the present printout reporting period.

MATIN is the total inflow of material to the pu during the present printout reporting period.

MATDIF is the net inflow (inflow-outflow) of material to the pu during the present printout reporting period.

---

ERROR/WARNING ID: 238 1

The continuity error reported below is greater than 1 part in 1000 and is therefore considered high.

Did you specify any "special actions"? If so, they could account for it.

Relevant data are:

DATE/TIME: 2002/ 8/31 24: 0

RCHRES : 1

RELERR	STORS	STOR	MATIN	MATDIF
-2.464E-02	0.00000	0.0000E+00	0.00000	-2.441E-09

Where:

RELERR is the relative error (ERROR/REFVAL).

ERROR is (STOR-STORS) - MATDIF.

REFVAL is the reference value (STORS+MATIN).

STOR is the storage of material in the processing unit (land-segment or reach/reservoir) at the end of the present interval.

STORS is the storage of material in the pu at the start of the present printout reporting period.

MATIN is the total inflow of material to the pu during the present printout reporting period.

MATDIF is the net inflow (inflow-outflow) of material to the pu during the present printout reporting period.

---

ERROR/WARNING ID: 238 1

The continuity error reported below is greater than 1 part in 1000 and is therefore considered high.

Did you specify any "special actions"? If so, they could account for it.

Relevant data are:



DATE/TIME: 2004/ 7/31 24: 0

RCHRES : 1

RELERR	STORS	STOR	MATIN	MATDIF
-7.063E-03	0.00000	0.0000E+00	0.00000	-8.521E-09

Where:

RELERR is the relative error (ERROR/REFVAL).  
ERROR is (STOR-STORS) - MATDIF.  
REFVAL is the reference value (STORS+MATIN).  
STOR is the storage of material in the processing unit (land-segment or reach/reservior) at the end of the present interval.  
STORS is the storage of material in the pu at the start of the present printout reporting period.  
MATIN is the total inflow of material to the pu during the present printout reporting period.  
MATDIF is the net inflow (inflow-outflow) of material to the pu during the present printout reporting period.

---

ERROR/WARNING ID: 238 1

The continuity error reported below is greater than 1 part in 1000 and is therefore considered high.

Did you specify any "special actions"? If so, they could account for it.

Relevant data are:

DATE/TIME: 2006/ 7/31 24: 0

RCHRES : 1

RELERR	STORS	STOR	MATIN	MATDIF
-2.065E-02	0.00000	0.0000E+00	0.00000	-2.878E-09

Where:

RELERR is the relative error (ERROR/REFVAL).  
ERROR is (STOR-STORS) - MATDIF.  
REFVAL is the reference value (STORS+MATIN).  
STOR is the storage of material in the processing unit (land-segment or reach/reservior) at the end of the present interval.  
STORS is the storage of material in the pu at the start of the present printout reporting period.  
MATIN is the total inflow of material to the pu during the present printout reporting period.  
MATDIF is the net inflow (inflow-outflow) of material to the pu during the present printout reporting period.

## *Disclaimer*

### *Legal Notice*

This program and accompanying documentation are provided 'as-is' without warranty of any kind. The entire risk regarding the performance and results of this program is assumed by End User. Clear Creek Solutions Inc. and the governmental licensee or sublicensees disclaim all warranties, either expressed or implied, including but not limited to implied warranties of program and accompanying documentation. In no event shall Clear Creek Solutions Inc. be liable for any damages whatsoever (including without limitation to damages for loss of business profits, loss of business information, business interruption, and the like) arising out of the use of, or inability to use this program even if Clear Creek Solutions Inc. or their authorized representatives have been advised of the possibility of such damages. Software Copyright © by : Clear Creek Solutions, Inc. 2005-2022; All Rights Reserved.

Clear Creek Solutions, Inc.  
6200 Capitol Blvd. Ste F  
Olympia, WA. 98501  
Toll Free 1(866)943-0304  
Local (360)943-0304

[www.clearcreeksolutions.com](http://www.clearcreeksolutions.com)

DRAFT

APPENDIX D: Stormwater Site Plan

**FOUNDATION DRAINAGE NOTES**

- ALL FOUNDATION DRAINAGE CLEANOUTS SHALL BE AS INDICATED WITH LIDS MARKED "FD".
- PROVIDE DUCTILE IRON SLEEVES WHERE FOUNDATION AND UNDERSLAB DRAINS PASS BELOW FOOTINGS. SEE STRUCTURAL DRAWINGS FOR ADDITIONAL REQUIREMENTS FOR PIPES PASSING BELOW FOOTINGS.
- SEE THE STRUCTURAL DRAWINGS FOR BUILDING FOUNDATION AND FOOTING SIZES, SLAB ON GRADE DEPTH AND FOUNDATION AND SLAB ON GRADE ELEVATIONS.
- FOUNDATION DRAINS SHALL BE SLOPED IN THE DIRECTION INDICATED WITH A MINIMUM SLOPE OF 0.50 PERCENT UNLESS NOTED OTHERWISE.
- UNLESS NOTED OTHERWISE, THE CONTRACTOR MAY USE ANY COMBINATION OF PREFABRICATED FITTINGS (TEES, BENDS AND WYES) FOR INSTALLATION OF THE FOUNDATION AND UNDERSLAB DRAINS. PREFABRICATED FITTINGS MAY BE ADJUSTED AS REQUIRED TO MAINTAIN POSITIVE SLOPE AND DRAINAGE. WHERE SPECIFICALLY INDICATED THE CONTRACTOR SHALL PROVIDE THE FITTINGS AS SHOWN.
- NO FOUNDATION DRAINAGE SHALL PASS THROUGH A BUILDING FOUNDATION WALL OR FOOTING WITHOUT PRIOR APPROVAL OF THE STRUCTURAL ENGINEER.
- CLEANOUTS SHALL BE SPACED NO GREATER THAN 100 FEET ON CENTER.

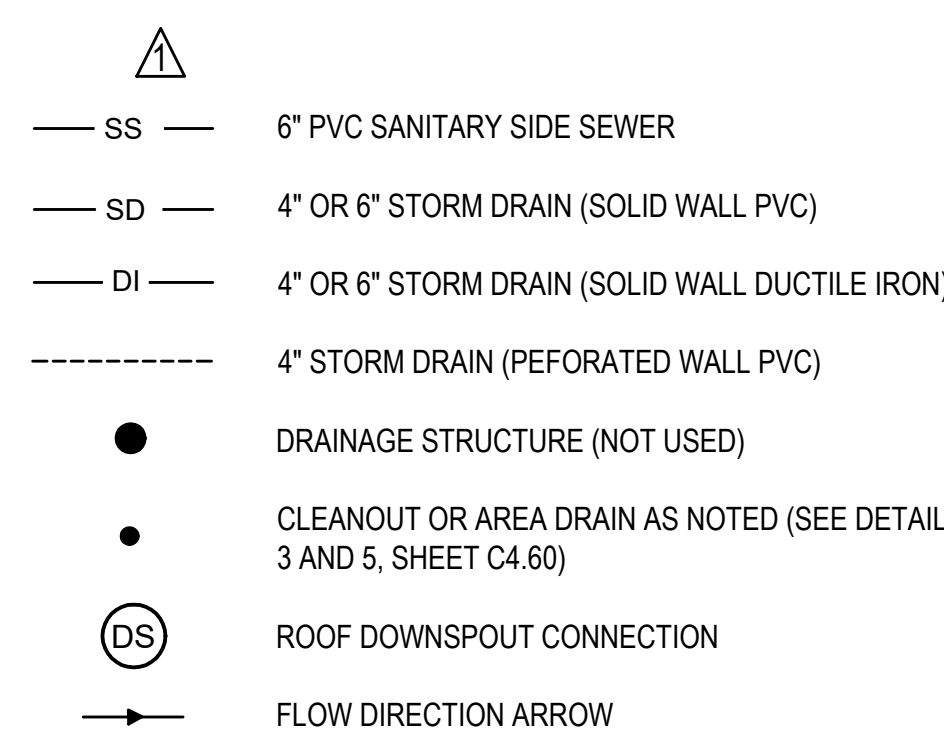
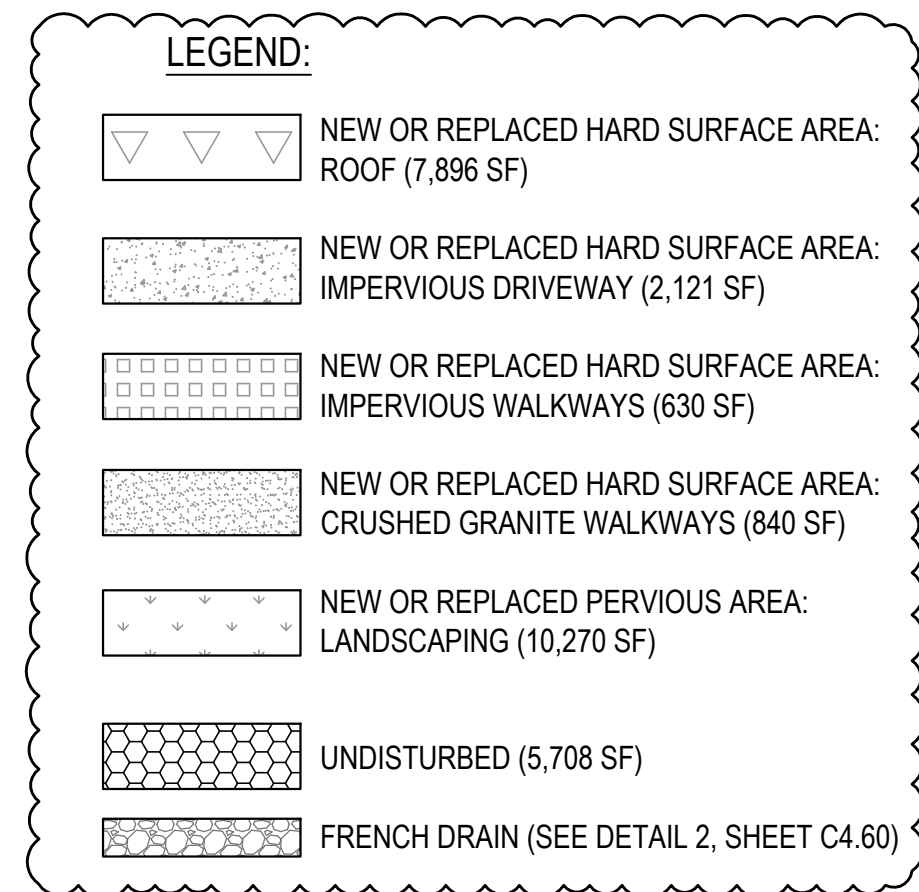

**STORM DRAINAGE NOTES**

- A COPY OF THE APPROVED DRAINAGE CONTROL PLANS MUST BE ON THE JOB SITE WHENEVER CONSTRUCTION IS IN PROGRESS.
- ALL REQUIRED STORM WATER FACILITIES MUST BE CONSTRUCTED AND IN OPERATION PRIOR TO ANY PAVING UNLESS OTHERWISE APPROVED BY THE DEPARTMENT OF PLANNING AND DEVELOPMENT.
- INSTALL CATCH BASIN INSERTS UNDER ALL CATCH BASIN AND AREA DRAIN GRATES IMMEDIATELY AFTER INSTALLATION. PROTECTION SHALL BE REMOVED AFTER FINAL PAVING AND/OR LANDSCAPING HAS BEEN ESTABLISHED.
- TOP ELEVATION FOR ALL CATCH BASINS WITH SOLID COVER SHALL MATCH FINISH GRADE.
- UNLESS NOTED OTHERWISE, THE CONTRACTOR MAY USE ANY COMBINATION OF PREFABRICATED FITTINGS (TEES, BENDS AND WYES) AT LOCATIONS WHERE STORM CONNECTION POINTS OF INTERSECTION (PI) ARE INDICATED. PREFABRICATED FITTINGS MAY BE ADJUSTED AS REQUIRED TO MAINTAIN POSITIVE SLOPE AND DRAINAGE. WHERE SPECIFICALLY INDICATED, THE CONTRACTOR SHALL PROVIDE THE FITTINGS AS SHOWN.
- COORDINATE POINTS AND ELEVATIONS SHOWN FOR ALL CATCH BASINS, CLEANOUTS, AREA DRAINS AND MANHOLES ARE TO THE CENTER OF THE FRAME AND GRATE OR COVER, UNLESS NOTED OTHERWISE.
- ALL TRENCHING FOR STORM DRAINS SHALL CONFORM TO CITY OF MERCER ISLAND STANDARD DETAILS S-3 AND S-4.
- ALL STORM DRAIN PIPING SHALL BE INSTALLED WITH A MINIMUM SLOPE OF 1.0 PERCENT.
- ALL STORM DRAIN MANHOLES ARE 48 INCHES IN DIAMETER, UNLESS NOTED OTHERWISE.
- VERIFY LOCATIONS OF LATERAL BUILDING CONNECTIONS WITH THE PLUMBING DRAWINGS PRIOR TO INSTALLATION.
- TOP ELEVATION FOR ALL VAULTS SHALL MATCH FINISH GRADE. SLOPE VAULT LIDS AS REQUIRED.
- PIPE AND DRAINAGE STRUCTURE MATERIALS SHALL BE AS FOLLOWS:
  - SOLID WALL STORM DRAIN PIPE SHALL BE PVC SDR 35, ASTM D3034.
  - DUCTILE IRON STORM DRAIN PIPE SHALL BE CEMENT-MORTAR LINED (DOUBLE THICKNESS) PER CITY OF SEATTLE STANDARD SPECIFICATION SECTION 9-05.3 "DUCTILE IRON PIPE".
  - PERFORATED SUBSURFACE DRAINAGE PIPE SHALL BE PER THE "SUBSURFACE FOUNDATION DRAINAGE" DETAIL 4, SHEET C4.60.
  - DRAINAGE STRUCTURES SHALL BE NYLOPLAST DRAIN BASIN WITH INSERTS, TEE AND ENVIROHOOD (NYLOPLAST DRAWING 7004-110-100, REV 'D') ON DOWNSTREAM PIPE OUTLETS. 18" DIAMETER OR APPROVED EQUAL PROVIDE 2-FOOT DEEP SUMP BELOW LOWEST CONNECTING PIPE INVERT ELEVATION. INSTALL STRUCTURE AND FRAME IN CONFORMANCE WITH MANUFACTURER'S RECOMMENDATIONS.
    - DRAINAGE STRUCTURES SHALL INCLUDE H-20 RATED INTEGRATED DUCTILE IRON FRAME AND COVER.
- CLEANOUTS SHALL BE PER DETAIL 5, SHEET C4.60 UNLESS NOTED OTHERWISE.
- AREA DRAINS SHALL BE PER DETAIL 3, SHEET C4.60 UNLESS NOTED OTHERWISE.
- PRIOR TO COMMENCEMENT OF STORM DRAIN INSTALLATION, CONTRACTOR SHALL POthOLE THE EXISTING WATER MAIN AT THE CROSSING OF THE NEW STORM DRAIN CONNECTION IN 79TH AVE SE, AND PROVIDE TOP AND BOTTOM OF WATER MAIN ELEVATIONS TO THE OWNER FOR VERIFICATION OF DESIGN.
  - IN THE EVENT THAT THE VERTICAL CLEARANCE BETWEEN THE STORM DRAIN PIPE AND WATER MAIN IS LESS THAN 12", THE PROJECT MUST STOP STORM DRAIN WORK. THE ENGINEER MUST SUBMIT A REVISION FOR THE CITY ENGINEER TO REVIEW AND APPROVE BEFORE PROCEEDING.
- STORMWATER PUMP SYSTEM NOTES:
  - AN EMERGENCY ON-SITE, BACKUP POWER SUPPLY AND AN EXTERNAL ALARM SYSTEM FOR SYSTEM FAILURE AND HIGH WATER LEVEL INDICATOR ARE REQUIRED FOR THE PUMP SYSTEM.
  - PRIVATE PROPERTY OWNERS SHALL BE RESPONSIBLE FOR ANY AND ALL CLAIMS FOR INJURIES AND DAMAGE DUE TO THE OPERATION OR NON-OPERATION OF THE PUMP SYSTEM.



3-21-2022

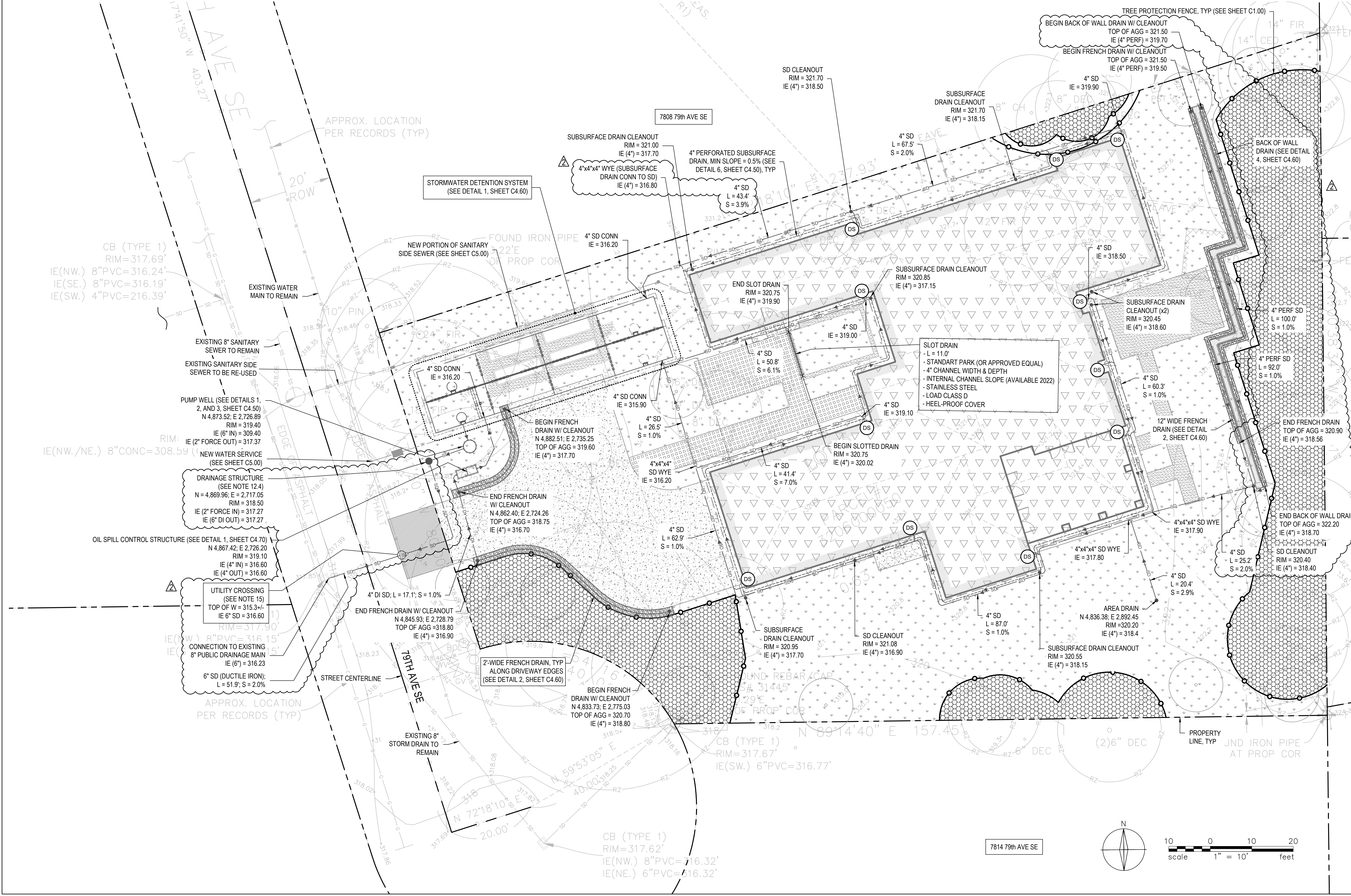

DESIGN	HL	
DRAWN	HL	
CHECKED	HL	
SHEET ISSUE DATE	03.07.2022	
<b>DRAWING SETS</b>		
PRE-APPLICATION	09/23/21	
PERMIT	03/07/22	
SET TITLE	DATE	
SET TITLE	DATE	
<b>REVISIONS</b>		
#	DATE	DESCRIPTION
1	07.29.22	BLDG PERMIT REV 01
2	09.21.22	BLDG PERMIT REV 02

**HL ENGINEERING**  
 6040 California Ave SW  
 Suite C  
 Seattle, WA 98136

**BRINDLEY RESIDENCE**

ADDRESS T.B.D.  
 7810 - 79th AVE SE  
 MERCER ISLAND, WA 98040

PERMIT DRAWINGS

**Stormwater Site Plan**

**C4.00**



9-21-2022

ITEM NO.	PART NUMBER	DESCRIPTION	QTY.
1	4936000	COVER, 36IN GALV STEEL BLANK, H2O TRAFFIC RATED	1
2	4967000	36" TRAFFIC RATED FIBERGLASS FLANGE	1
3	7078000	LABEL BARCODE 4x 2-2-1/2	1

NOTES:  
SHIP COVER OUT ON PALLET THAT COVER ARRIVED ON SHIP FLANGE LOOSE ON TOP OF COVER  
PLACE HARDWARE KIT FOR FLANGE (PRE-PACKAGED FROM TOPP) INSIDE FLANGE PRIOR TO WRAPPING.

dm by J.BURNS	tot: xx+/- .02"
date 02/10/21	xxx+/- .005"
scale	angles +/- .2°
title COVER 36 IN H2O TRAFFIC RATED BLANK WITH FIBERGLASS FLANGE	
part no. K001928	
drawing no. K001928	sheet number/sheet size 1 of 1 B

Liberty Pumps  
7000 APPLE TREE AVENUE  
BERGEN, N.Y. 14416  
(585) 494-1817

NEW PART	A	NA	02/10/21	JRB
description of change	rev	project	date	initials

DETAIL: STORMWATER PUMP WELL COVER  
NTS

DETAIL NO.: 1  
REF SHEET: C4.00

SECTION A-A  
SCALE 1 : 8

dm by R.DUNLAP	tot: xx+/- .02"
date 06/15/22	xxx+/- .005"
scale SEE NOTE	angles +/- .2°
title 36" TANK, FIBERGLASS, DS	
part no. SEE NOTE	
drawing no. 36DS	sheet number/sheet size 2 of C

DETAIL: STORMWATER PUMP AND WELL ASSEMBLY  
NTS

DETAIL NO.: 3  
REF SHEET: C4.00



**Product Quotation**

7000 Apple Tree Ave.  
Bergen NY 14416  
Phone: 800-543-2550  
Fax: 585-494-1839

Quote # EPS99926 Rev A  
By Jon Emasie  
Date September 15, 2022

To:   
Gordon and Assoc  
Attention:   
Kyle

Preassembled Duplex Sump System Model # EPS99926 Rev A

Qty	Item/Description
2	250-2 Sump pumps, 1/3 HP, 115 V, 1 phase, capacities of 50 GPM, heads to 22' TDH, 25' power cord
1	AE24L=3 NEMA 4X duplex alternating control panel including three floats, aux. contacts, and integral audio/visual high level alarm
1	36" dia. X 120" H fiberglass basin with Fiberglass anti-floatation flange with 2" side discharge, 2" Female Threaded PVC discharge coupling.
1	36" Steel Blank cover Traffic Rated
1	XF36000 Fiberglass flange for H2O traffic rated covers
2	Guide rail assembly, including Campbell-Hausfeld guide rail, 3/4" stainless steel rails, s/s lifting chain, etc. (1) 4" Unmounted inlet hub
1	Miscellaneous hardware and plumbing, including PVC ball valves, PVC check valves, float bracket, PVC discharge pipe etc.
1	JB70 junction box, with watertight cable connectors and 2" conduit coupling
1	Labor & Fabrication

**Complete System List Price: \$29,146.00**

Subject to approval, pump performance and materials of construction may vary. Please consult factory and / or product literature for actual performance and material of construction. Pump system startup not included on this quote, to be provided by others.

**Warranty** 3 Years  
**Freight** Prepaid on orders over \$3000.00 Net US for standard shipments. Jobsite deliveries may require additional charges  
**Shipping** \*Please check with factory before ordering for current lead times\*  
**Returns** Will incur a 25% restocking fee (custom items incur a 100% restocking fee)  
**Price** Quoted prices valid for 30 days

NOTE: LIFTER CHAINS AND FLOATS, NOT SHOWN, PUMPS SHIPPED SEPARATELY TO PREVENT SYSTEM DAMAGE.

**EPS99926**  
36X120 DUPLEX 250-2 EFFLUENT SYSTEM

NOTE: COORDINATE WITH MANUFACTURER ON REDUCED OUTLET DEPTH, REQUIRED DUE TO SHALLOW CITY MAIN

NOTE: FORCE OUT = 317.37

NOTE: RIM = 319.40

NOTE: IE (6" IN) = 309.40

NOTE: IE (2" FORCE OUT) = 317.37

NOTE: 2" FORCE OUT = 317.37

NOTE: 1-1/2" SCH80 PVC PIPE

NOTE: (2) 250-2 1/3HP, 115 V, 1PH

NOTE: (1) 4" Unmounted inlet AE24L=3

NOTE: FIBERGLASS TANK dimension tolerance(s): +/- .1"

NOTE: Custom items are non-cancelable once order is placed. 100% restocking fee applies

PROPRIETARY AND CONFIDENTIAL  
THE INFORMATION CONTAINED IN THIS DRAWING IS THE SOLE PROPERTY OF LIBERTY PUMPS. ANY REPRODUCTION IN PART OR AS A WHOLE WITHOUT THE WRITTEN PERMISSION OF LIBERTY PUMPS IS PROHIBITED.

7000 APPLE TREE AVENUE  
BERGEN, N.Y. 14416  
(585) 494-1817

QUOTED PROVIDED BY: J.Emasie

CUSTOMER APPROVAL  
DATE: \_\_\_\_\_  
NAME(PRINT): \_\_\_\_\_  
NAME(SIGN): \_\_\_\_\_  
FINAL CONFIGURATIONS MAY VARY SLIGHTLY FROM THE ILLUSTRATIONS ON THIS PRINT

**STORMWATER PUMP SELECTION AND NOTES**

- PUMP MODEL: LIBERTY PUMPS 240-SERIES SUBMERSIBLE (OR APPROVED EQUAL)
- PUMP OPERATION: DUPLEX ALTERNATING ONE PUMP DURING NORMAL CONDITIONS, TWO PUMPS RUNNING DURING HIGH ALARM
- DESIGN POINT: TBD
- POWER REQUIREMENT: 1/3 HP, 115V, 6 AMP
- CONTROL PANEL: NEMA 4X
- ON/OFF MECHANISM: THREE FLOATS, SET OFF / ON AT LEAST 12" APART TO PREVENT CYCLING

**NOTES TO INSTALLER**

- SEE SHEET C4.00 FOR PUMP INSTALLATION LOCATION
- SEE SHEET C4.00 FOR DISCHARGE LOCATION
- FORCE MAIN TO BE 1-1/2" DIAMETER PVC WITH PRESSURE RATINGS OF AT LEAST 40 PSI
- COORDINATE WITH PUMP VENDOR TO ACQUIRE ALL MATERIALS NEEDED FOR INSTALLATION, INCLUDING ELECTRICAL CABLES, FLOATS, INLET/OUTLET PENETRATIONS, BRACKETS OR RAILS FOR PUMPS, DISCHARGE CHECK VALVE, ETC.
- SET PUMP OFF ELEVATION WITH 12" SUMP TO ALLOW FOR SOLIDS ACCUMULATION

DETAIL: STORMWATER PUMP AND WELL ASSEMBLY QUOTE  
NTS

DETAIL NO.: 2  
REF SHEET: C4.00

DESIGN	HL
DRAWN	HL
CHECKED	HL
SHEET ISSUE DATE	03.07.2022
PRE-APPLICATION	09/23/21
PERMIT	03/07/22
SET TITLE	DATE
SET TITLE	DATE

#	DATE	DESCRIPTION
1	07.29.22	BLDG PERMIT REV 01
2	09.21.22	BLDG PERMIT REV 02

**HL ENGINEERING**  
6040 California Ave SW  
Suite C  
Seattle, WA 98136

**BRINDLEY RESIDENCE**

ADDRESS T.B.D.  
7810 - 79th AVE SE  
MERCER ISLAND,  
WA 98040

**PERMIT DRAWINGS**

**Stormwater Pump and Well Details**

**C4.50**



9-21-2022

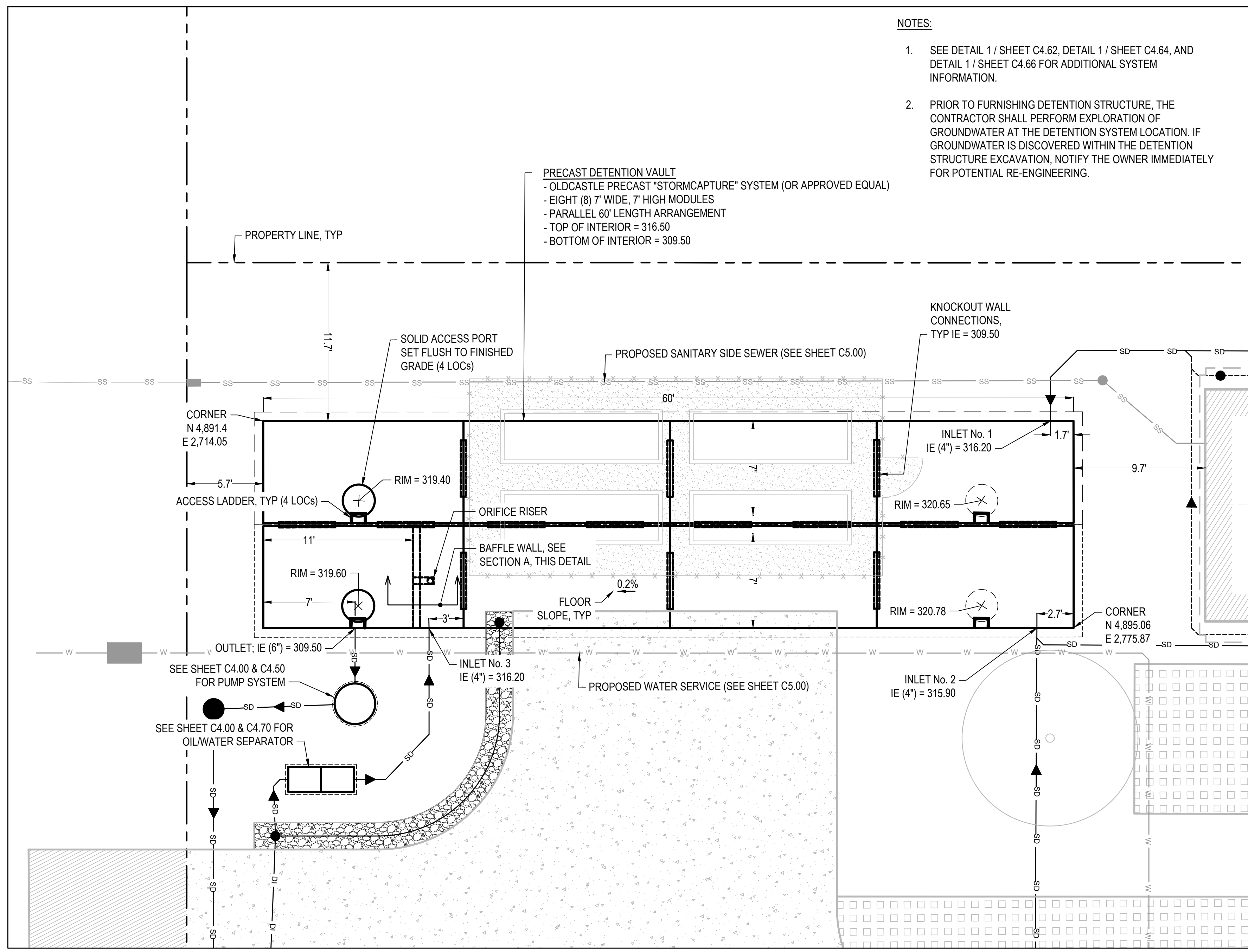

- NOTES:**
- SEE DETAIL 1 / SHEET C4.62, DETAIL 1 / SHEET C4.64, AND DETAIL 1 / SHEET C4.65 FOR ADDITIONAL SYSTEM INFORMATION.
  - PRIOR TO FURNISHING DETENTION STRUCTURE, THE CONTRACTOR SHALL PERFORM EXPLORATION OF GROUNDWATER AT THE DETENTION SYSTEM LOCATION. IF GROUNDWATER IS DISCOVERED WITHIN THE DETENTION STRUCTURE EXCAVATION, NOTIFY THE OWNER IMMEDIATELY FOR POTENTIAL RE-ENGINEERING.

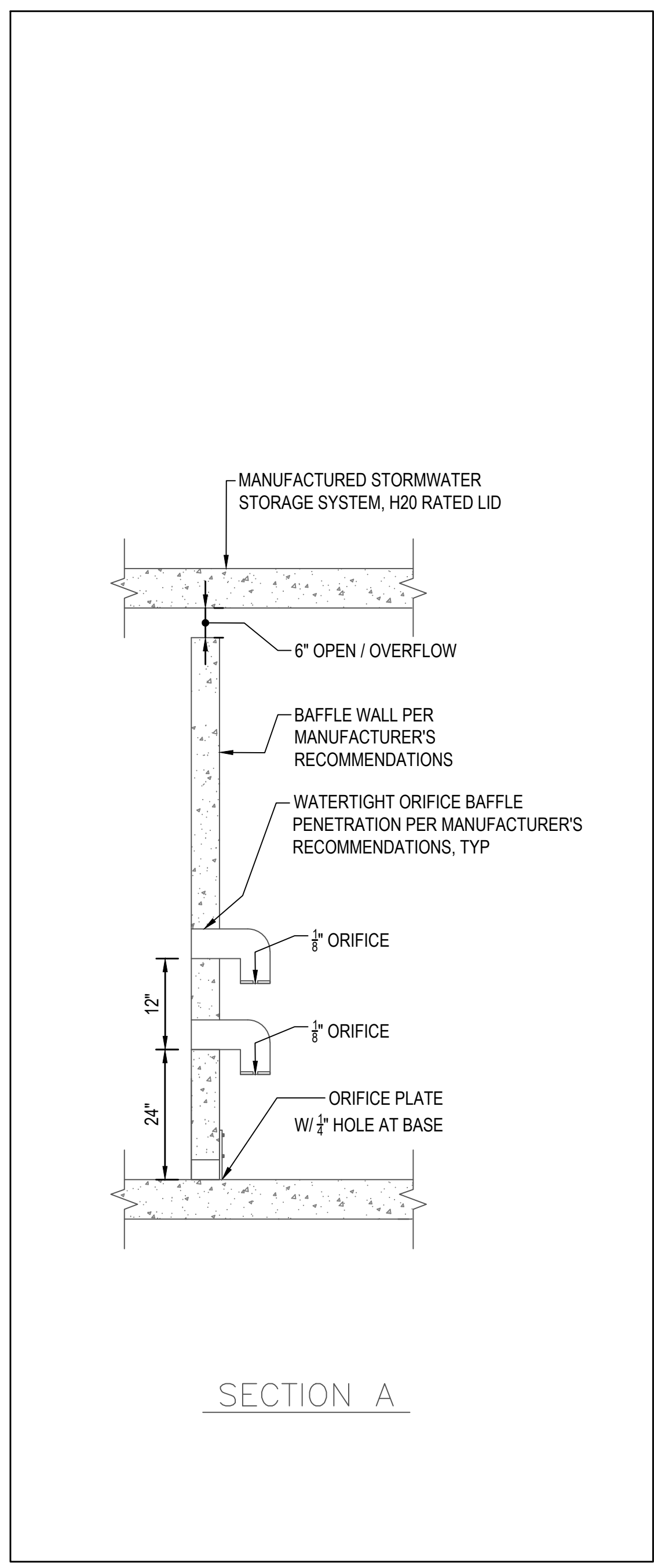

DETAIL: STORMWATER DETENTION SYSTEM  
NTS

DETAIL NO.: 1  
REF SHEET: C4.00

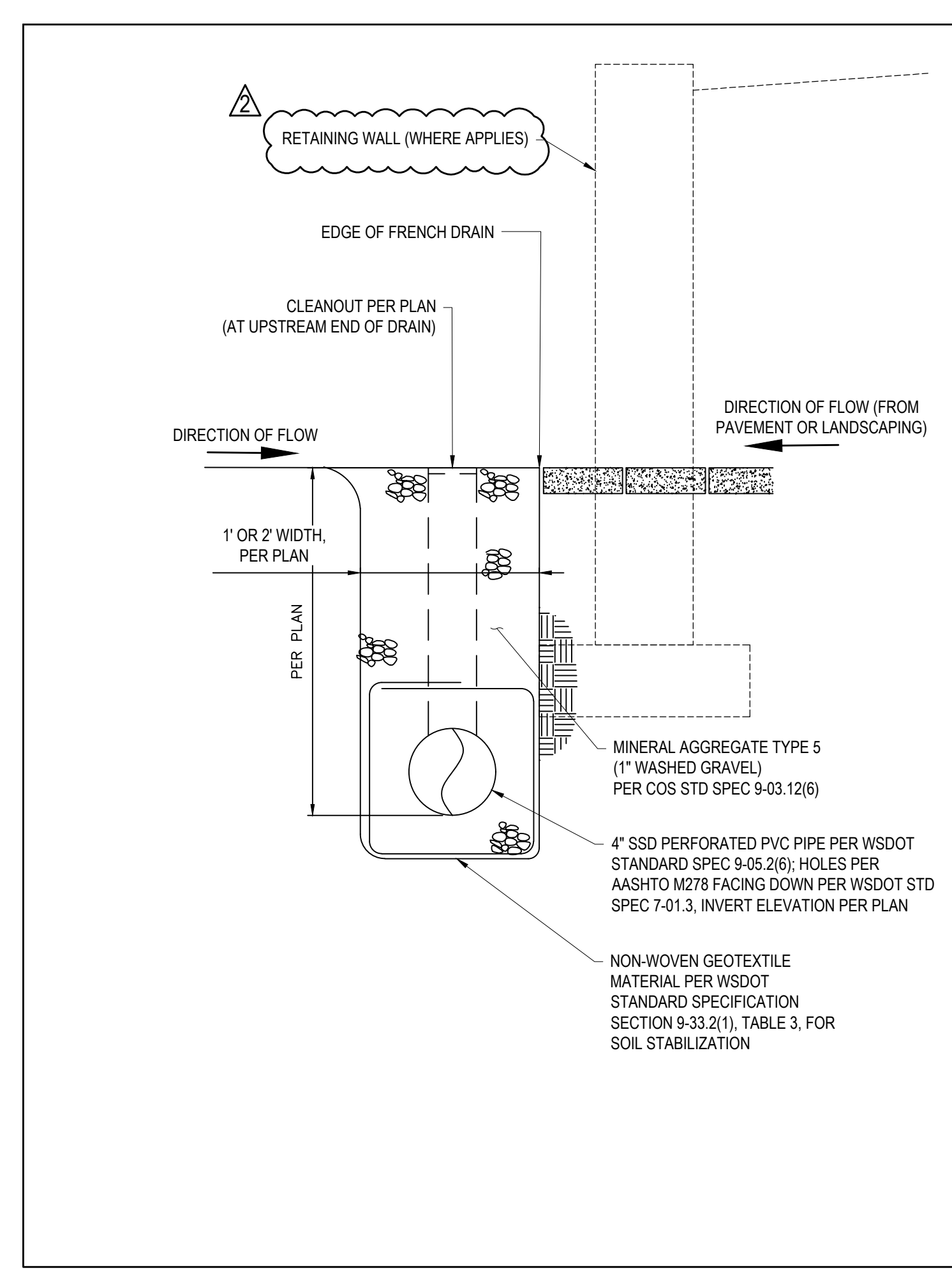

DETAIL: FRENCH DRAIN  
NTS

DETAIL NO.: 2  
REF SHEET: C4.00

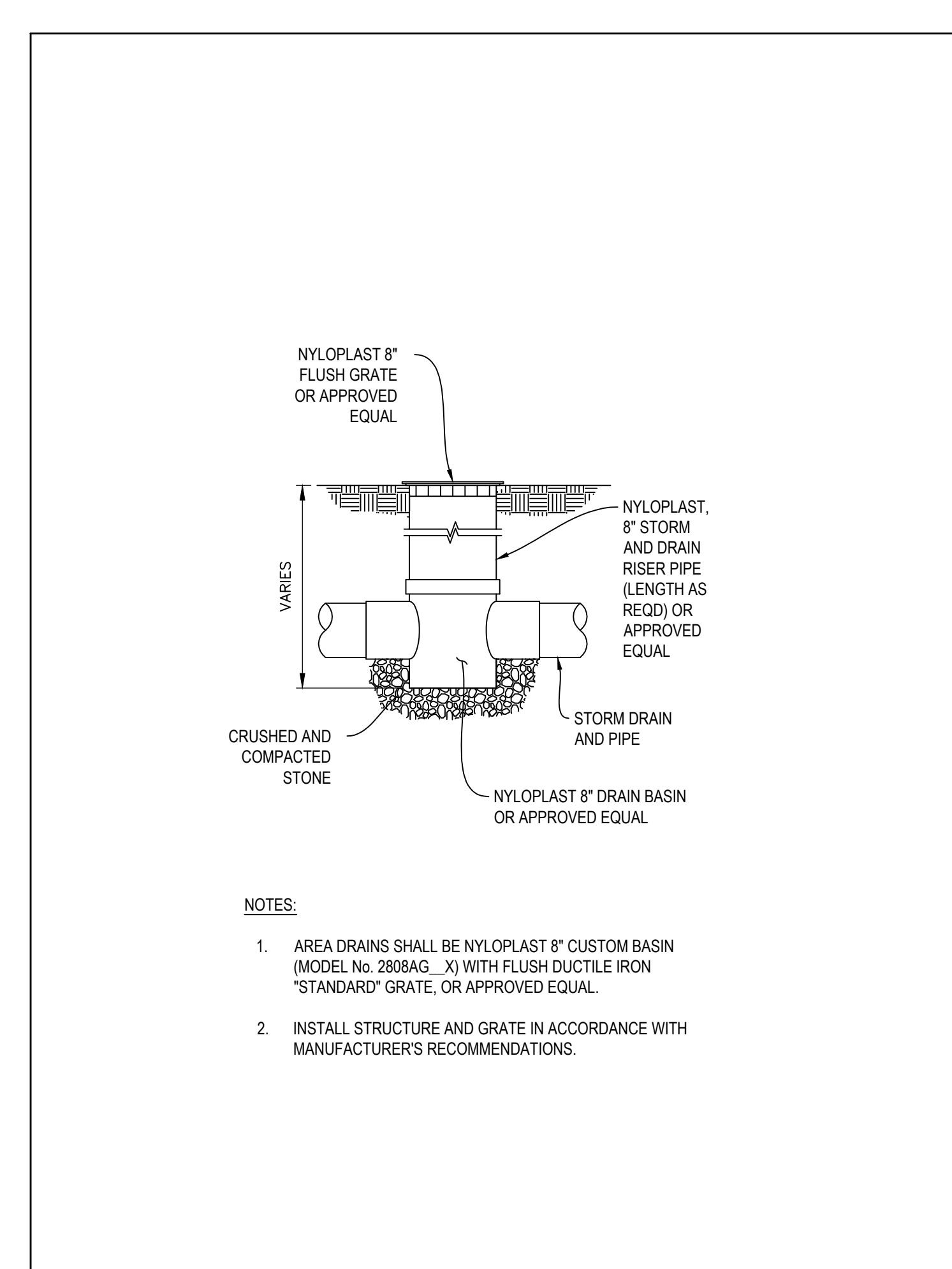

DETAIL: AREA DRAIN  
NTS

DETAIL NO.: 3  
REF SHEET: C4.00

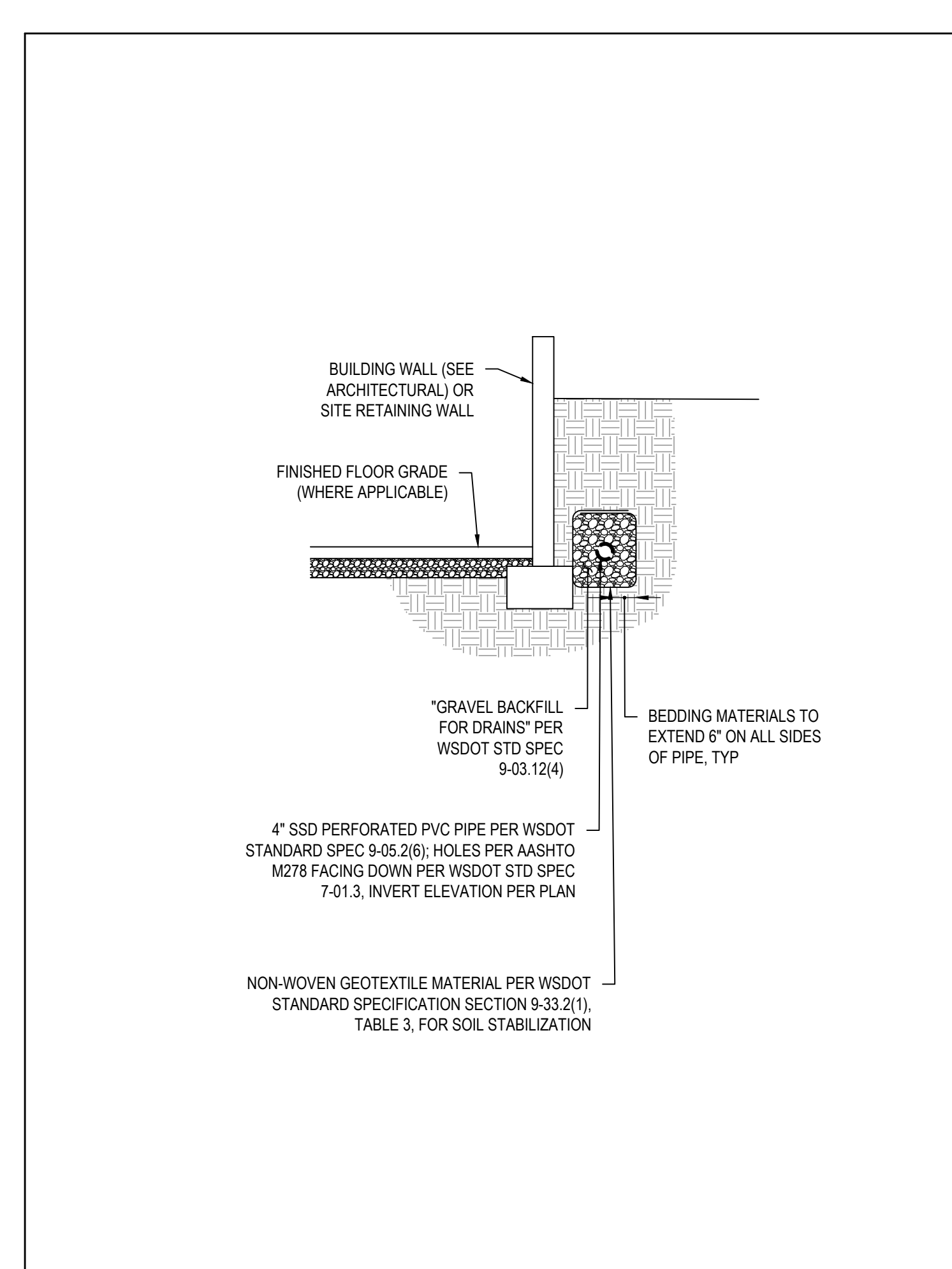

DETAIL: SUBSURFACE FOUNDATION DRAIN  
NTS

DETAIL NO.: 4  
REF SHEET: C4.00

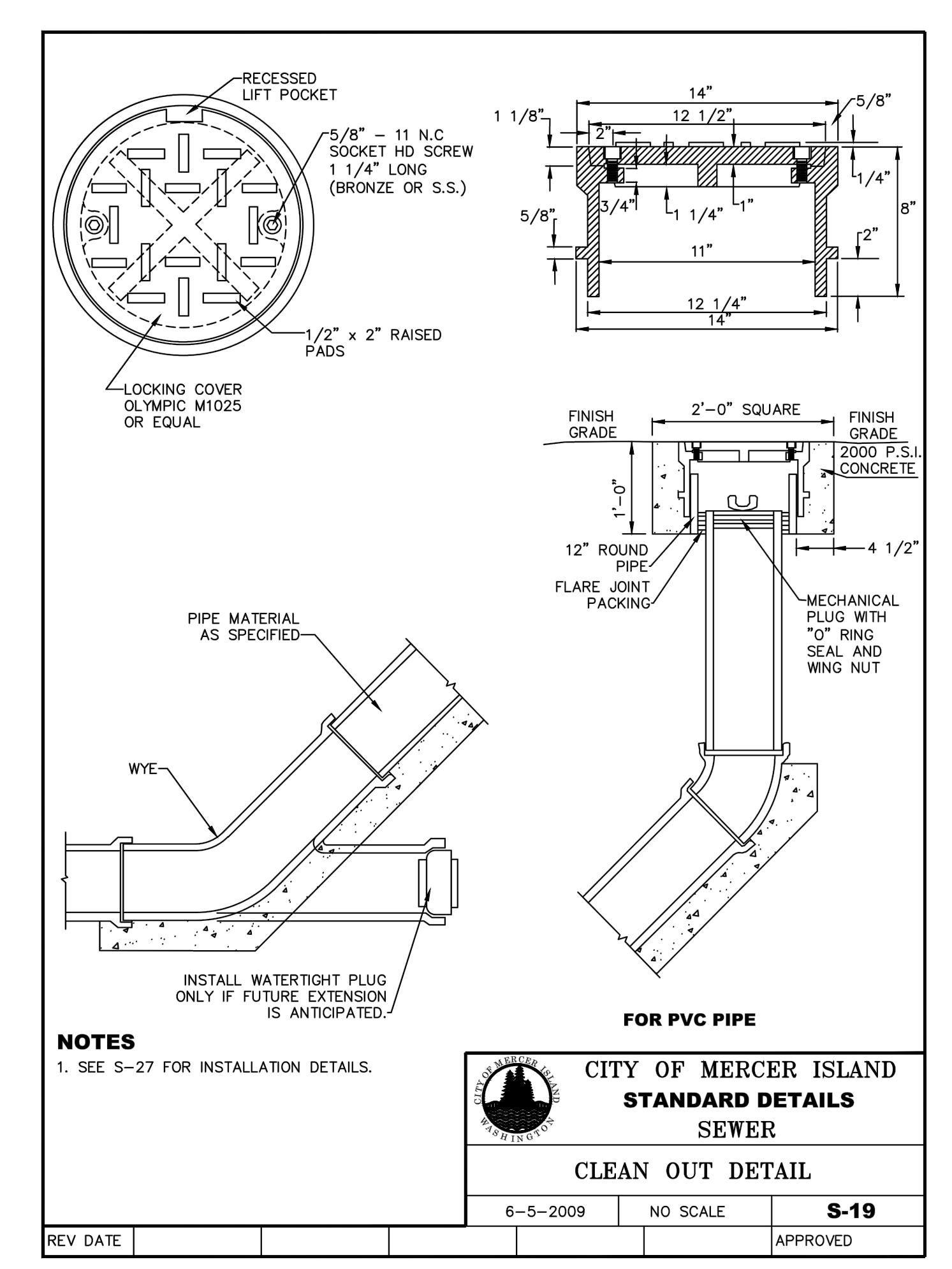

DETAIL: PRIVATE UTILITY CLEANOUT  
NTS

DETAIL NO.: 5  
REF SHEET: C4.00

DESIGN	HL	
DRAWN	HL	
CHECKED	HL	
SHEET ISSUE DATE	03.07.2022	
<b>DRAWING SETS</b>		
PRE-APPLICATION	09/23/21	
PERMIT	03/07/22	
SET TITLE	DATE	
SET TITLE	DATE	
<b>REVISIONS</b>		
#	DATE	DESCRIPTION
1	07.29.22	BLDG PERMIT REV 01
2	09.21.22	BLDG PERMIT REV 02

**HL ENGINEERING**  
6040 California Ave SW  
Suite C  
Seattle, WA 98136

**BRINDLEY RESIDENCE**

ADDRESS T.B.D.  
7810 - 79th AVE SE  
MERCER ISLAND,  
WA 98040

PERMIT DRAWINGS  
**Stormwater Detention System Details**

**C4.60**



9-21-2022

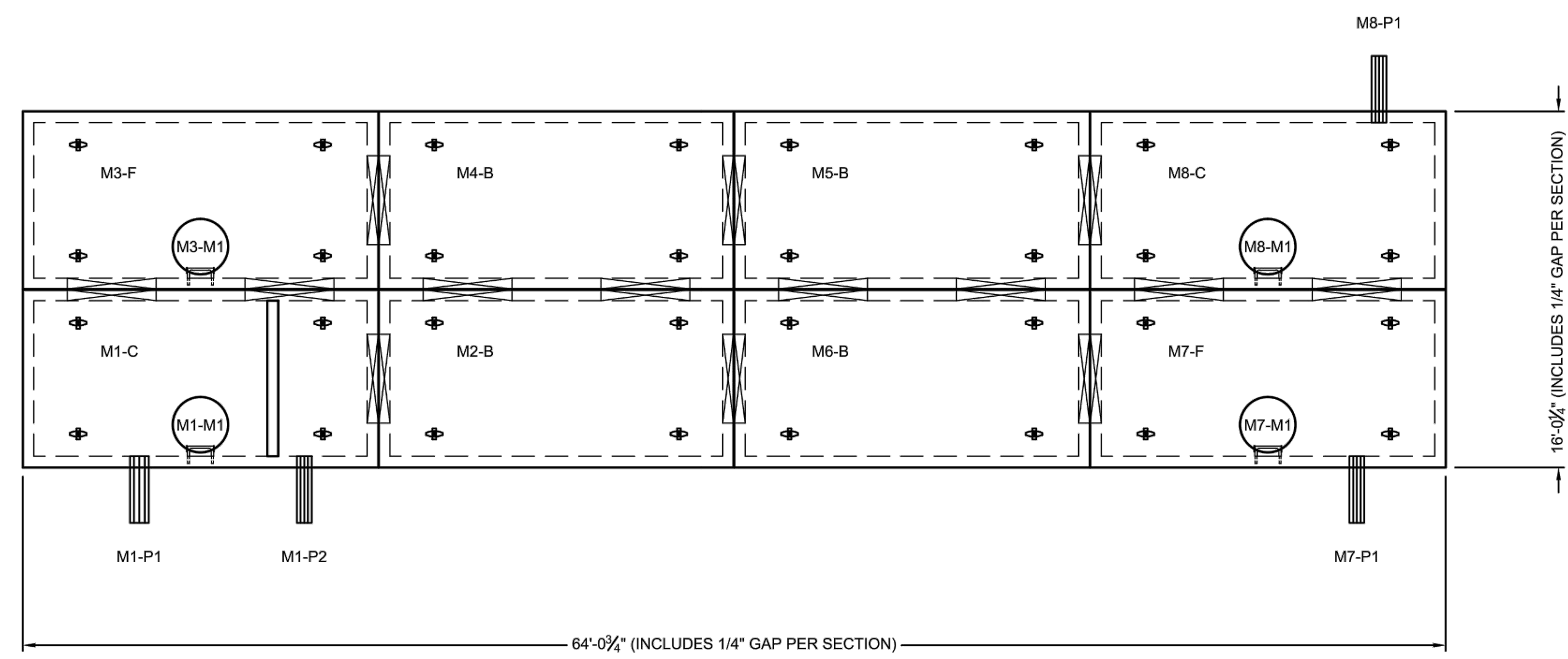

PLAN VIEW  
SCALE: 1/8" = 1'-0"

- DESIGN NOTES**
- LIVE LOADING CRITERIA:
    - AASHTO HS-20-44 DESIGN TRUCK (WITH IMPACT AT 0.50FT MINIMUM COVER)
    - LATERAL LIVE LOAD SURCHARGE: 80 PSF (TO 0.90FT DEPTH)
    - NO LATERAL SURCHARGE(S) FROM ANY ADJACENT BUILDINGS, WALLS, FOUNDATIONS, OR ANY ADDITIONAL SITE ELEMENTS.
  - SOIL LOADING CRITERIA:
    - SOIL COVER DEPTH: 0.50FT (MIN.) - 5.00FT (MAX.)
    - SOIL UNIT WEIGHT: 120 PCF
    - ASSUMED WATER TABLE ELEVATION: BELOW BOTTOM OF PRECAST
    - REQUIRED ALLOWABLE BEARING PRESSURE: 2,500 PSF
    - EQUIVALENT LATERAL FLUID PRESSURE, ACTIVE: 45 PCF (DRAINED)
    - EQUIVALENT LATERAL FLUID PRESSURE, AT-REST: 60 PCF (DRAINED)
    - EQUIVALENT LATERAL FLUID PRESSURE, PASSIVE: 150 PCF (DRAINED)
    - ASSUMED COEFFICIENT OF FRICTION: 0.40
    - SEISMIC LATERAL EARTH PRESSURES: NOT APPLICABLE
  - STORMCAPTURE MODULE TYPE: DETENTION (WATERTIGHT).
  - CONCRETE (NORMAL WEIGHT):
    - MIN. 28-DAY COMPRESSIVE STRENGTH: 6,000 PSI
    - CEMENT: ASTM C150
  - STEEL REINFORCEMENT: ASTM A615 / A706 (GRADE 60), ASTM A1064 (GRADE 80)
  - REFERENCE STANDARDS: ASTM C913 & C890, ACI 318-14

**MODULE NOTES**

TYPE	QUANTITY	HEIGHT
B	4	7.00'
C	2	7.00'
F	2	7.00'
TOTAL	8	
VOLUME	6.132	CUBIC FEET

**PIPE SCHEDULE**

PIPE	SIZE	INVERT
M1-P1	6" DIP	309.50'
M1-P2	4" PVC	316.20'
M7-P1	4" PVC	316.90'
M8-P1	4" PVC	316.20'

**MANHOLE SCHEDULE**

MANHOLE	TYPE	RIM
M1-M1	30" DIA. F&C Steps	0.00'
M3-M1	30" DIA. F&C Steps	0.00'
M7-M1	30" DIA. F&C Steps	0.00'
M8-M1	30" DIA. F&C Steps	0.00'

REV	DESCRIPTION	DATE

**Oldcastle Infrastructure**  
A PERI COMPANY

PH: 800.678.8819 | www.oldcastleinfrastructure.com/stormcapture

THIS DOCUMENT IS THE PROPERTY OF OLDCASTLE INFRASTRUCTURE, INC. IT IS CONFIDENTIAL, SUBMITTED FOR REFERENCE PURPOSES ONLY AND SHALL NOT BE USED IN ANY WAY IN VIOLATION TO THE INTERESTS OF, OR WITHOUT THE WRITTEN PERMISSION OF OLDCASTLE INFRASTRUCTURE, INC. COPYRIGHT © 2021 OLDCASTLE INFRASTRUCTURE, INC. ALL RIGHTS RESERVED.

STORMCAPTURE®	SYSTEM ID	PLAN N
DETENTION SYSTEM	1	

CUSTOMER:  
HL Engineering

JOB NAME:  
7810 79th Ave SE

DATE: 9/15/2022

SALES: -

DRAWN: -

ENGINEER: -

CHECKED: -

SALES ORDER: -

DRAWING NAME: SC1 7-0

SHEET: 1 OF 3

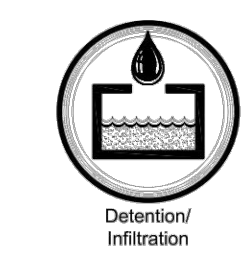

DESIGN	HL	
DRAWN	HL	
CHECKED	HL	
SHEET ISSUE DATE	03.07.2022	
DRAWING SETS		
PRE-APPLICATION	09/23/21	
PERMIT	03/07/22	
SET TITLE	DATE	
SET TITLE	DATE	
REVISIONS		
#	DATE	DESCRIPTION
1	07.29.22	BLDG PERMIT REV 01
2	09.21.22	BLDG PERMIT REV 02

**HL ENGINEERING**

6040 California Ave SW  
Suite C  
Seattle, WA 98136

**BRINDLEY RESIDENCE**

ADDRESS T.B.D.  
7810 - 79th AVE SE  
MERCER ISLAND,  
WA 98040

PERMIT DRAWINGS

**Stormwater Detention System Details**

**C4.62**



9-21-2022

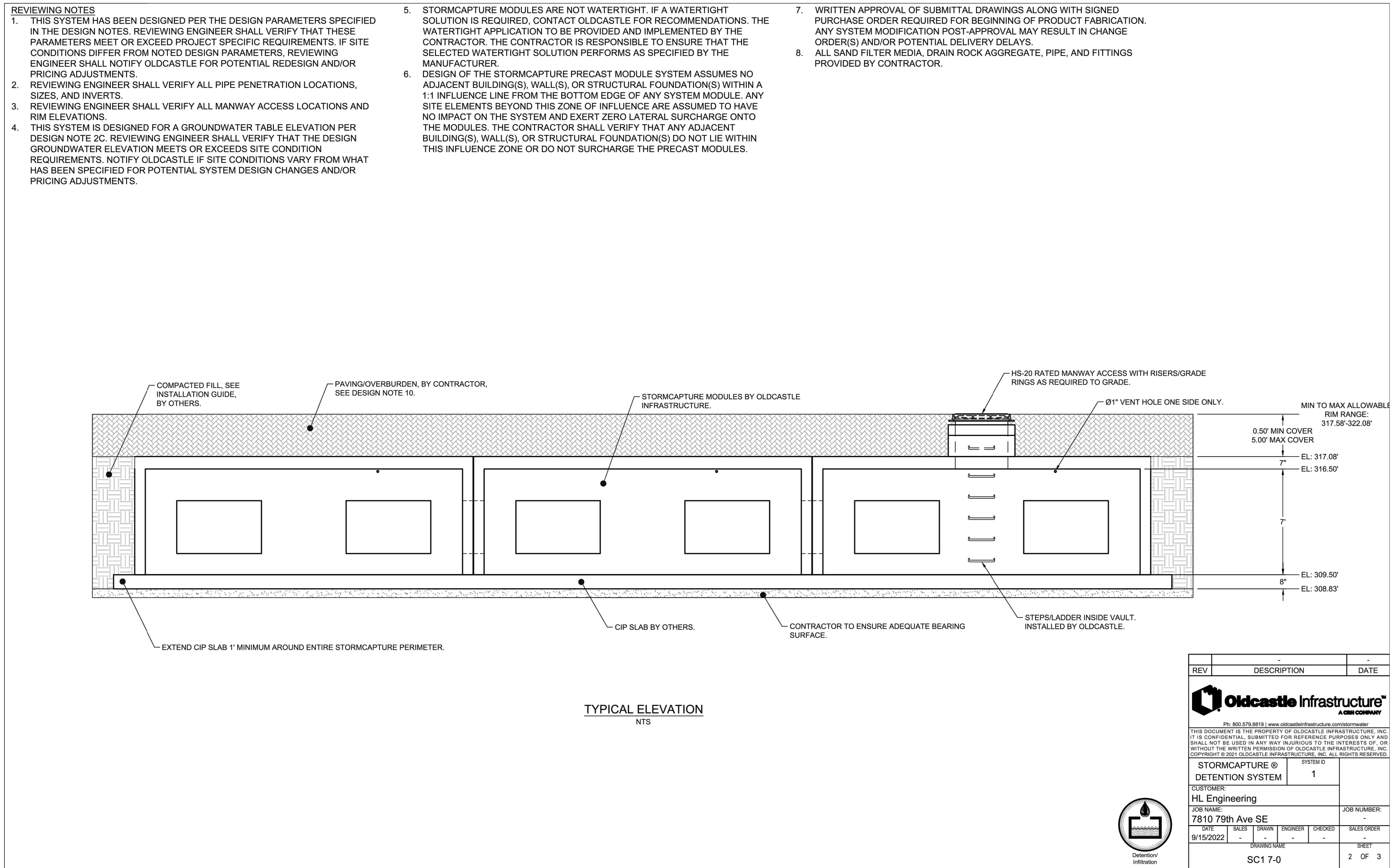

DESIGN	HL	
DRAWN	HL	
CHECKED	HL	
SHEET ISSUE DATE	03.07.2022	
<b>DRAWING SETS</b>		
PRE-APPLICATION	09/23/21	
PERMIT	03/07/22	
SET TITLE	DATE	
SET TITLE	DATE	
<b>REVISIONS</b>		
#	DATE	DESCRIPTION
1	07.29.22	BLDG PERMIT REV 01
2	09.21.22	BLDG PERMIT REV 02

**HL ENGINEERING**

6040 California Ave SW  
Suite C  
Seattle, WA 98136

**BRINDLEY RESIDENCE**

ADDRESS T.B.D.  
7810 - 79th AVE SE  
MERCER ISLAND,  
WA 98040

PERMIT DRAWINGS

**Stormwater Detention System Details**

**C4.64**





9-21-2022

- INSTALLATION NOTES**
- UNDERGROUND PRECAST CONCRETE SYSTEM INSTALLATION SHALL BE PER ASTM C891, "STANDARD PRACTICE FOR INSTALLATION OF UNDERGROUND PRECAST CONCRETE UTILITY STRUCTURES" AND PER OLDCASTLE.
  - MODULE SUBBASE OR SUBGRADE SHALL BE LEVEL/SCREEDED AND COMPACTED ADEQUATELY FOR REQUIRED BEARING CAPACITY PER DESIGN NOTE 2D. CONTRACTOR AND/OR INSTALLING SUB-CONTRACTOR SHALL VERIFY THAT SOIL BEARING CONDITIONS MEET OR EXCEED DESIGN REQUIRED MINIMUMS PRIOR TO PLACEMENT AND INSTALLATION OF MODULES.
  - ANY CONSTRUCTION EQUIPMENT EXCEEDING NOTED DESIGN LOADING IS NOT PERMITTED OVER OR ADJACENT TO ANY MODULE WITHOUT FORMAL REVIEW AND WRITTEN APPROVAL BY OLDCASTLE ENGINEERING. ELSE PRODUCT WARRANTY MAY BE VOIDED. ANY DESIGN CONSTRAINT EXCEEDING THE DESIGN PARAMETERS NOTED ABOVE MAY REQUIRE CUSTOM STRUCTURAL DESIGN, SUBGRADE REVISIONS, AND/OR PRICING ADJUSTMENTS.
  - HEAVY VIBRATORY COMPACTION EQUIPMENT SHALL NOT BE OPERATED WITHIN 10 FEET OF MODULE EXTERIOR.
  - MINIMUM OF 0.50 FT OF SOIL COVER REQUIRED FOR CONSTRUCTION EQUIPMENT OPERATION ON TOP OF SYSTEM. IT IS THE RESPONSIBILITY OF THE CONTRACTOR AND INSTALLING SUB-CONTRACTOR TO ENSURE THAT NO MODULES ARE DAMAGED DURING CONSTRUCTION.
  - UNLESS NOTED OTHERWISE, ALL PIPE SUPPLIED AND INSTALLED BY OTHERS. CONTRACTOR MAY MODIFY AT RISK ANY OLDCASTLE PRODUCT(S) IN THE FIELD OR AFTER DELIVERY WITHOUT FORMAL REVIEW AND WRITTEN APPROVAL BY OLDCASTLE ENGINEERING. THE CONTRACTOR SHALL BE RESPONSIBLE FOR VERIFYING THAT ANY PRODUCT MODIFICATIONS DO NOT INVALIDATE THE PRODUCT WARRANTY.
  - MODULE PLACEMENT FIELD TOLERANCES SHALL NOT EXCEED 3/4" BETWEEN ADJACENT MODULES. IF MODULE GAP EXCEEDS 3/4", CONTRACTOR SHALL MAKE NECESSARY ADJUSTMENTS AND RESET MODULE(S) TO BRING WITHIN NOTED TOLERANCES.
  - CONTRACTOR IS RESPONSIBLE FOR PRODUCTS ONCE DELIVERED TO THE SITE. OLDCASTLE IS NOT RESPONSIBLE FOR OFFLOADING PRODUCTS, MAINTENANCE, AND INSTALLATION OF PRODUCTS ONCE THEY ARRIVE TO THE SITE.
  - CONTRACTOR SHALL INSTALL SYSTEM PER PROJECT WATERPROOFING AND SOILTIGHTNESS REQUIREMENTS. WATERPROOFING AND SOILTIGHTNESS INSTALLATION IS NOT BY OLDCASTLE AND OLDCASTLE WILL PROVIDE NO GUARANTEE FOR THIS COMPONENT OF SYSTEM INSTALLATION.

KEYWAYS MUST BE FREE OF DIRT, ROCKS, AND WATER. ROCKS AND DIRT PREVENT THE VAULT SECTIONS FROM SEATING AND SEALING PROPERLY. REMOVE ALL PROTECTIVE PAPER FROM RUBBER SEALANT MATERIAL. SPLICE RUBBER SEALANT MATERIAL WITH A "SIDE BY SIDE" JOINT, AWAY FROM CORNERS. CORNER SPLICING WILL NOT SEAL PROPERLY.

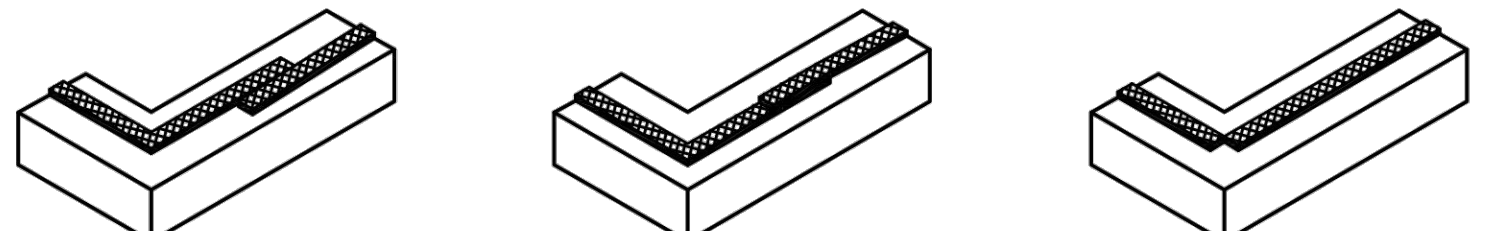

**CORRECT** - INSTALL RUBBER SEALANT MATERIAL AT THE OUTER EDGE OF THE KEYWAY. RUBBER SEALANT SHOULD BE CONTINUOUS AROUND CORNERS.

**INCORRECT** - DO NOT OVERLAP THE RUBBER SEALANT MATERIAL AT SPLICE.

**INCORRECT** - DO NOT SPLICE RUBBER SEALANT MATERIAL AT A CORNER. RUBBER SEALANT SHOULD BE CONTINUOUS AROUND CORNERS.

**BUTYL RUBBER SEALANT (CONSEAL CS-102 OR EQUAL) PLACEMENT DETAIL**  
N.T.S.

MAXIMUM EQUIPMENT OPERATING WEIGHT (OW) BY TRACK WIDTH				
TRACK WIDTH	12"	18"	24"	30"
MIN TRACK LENGTH	8'-0"	10'-0"	12'-0"	14'-0"
FILL DEPTH	OW (LBS)	OW (LBS)	OW (LBS)	OW (LBS)
0	35,000	45,000	52,500	54,500
1	35,000	45,000	56,000	60,500
2	35,000	45,000	56,000	64,000
3	76,000	78,500	83,500	88,000
4	94,000	100,000	106,000	113,000
5	100,000	116,000	132,000	149,000

- NOTES:**
- IF CONSTRUCTION EQUIPMENT EXCEEDS THE ABOVE OPERATING WEIGHT LIMITS REFER TO INSTALLATION NOTE 3.
  - FOR WHEELED CONSTRUCTION EQUIPMENT LIMITS REFER TO INSTALLATION NOTE 3.
  - MINIMUM AXLE SPACING FOR ALL TRACK WIDTHS IS 6'-0".

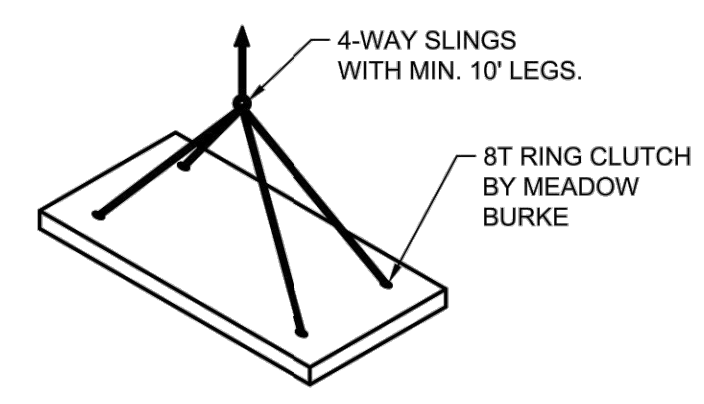

**LINK SLAB LIFTING DETAIL**  
N.T.S.

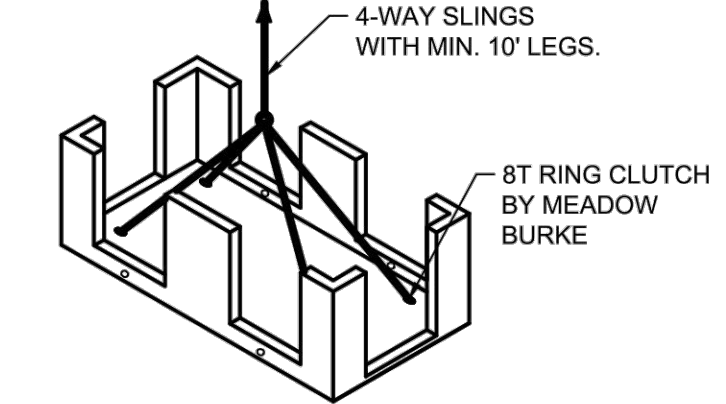

**BOTTOM MODULE LIFTING DETAIL**  
N.T.S.

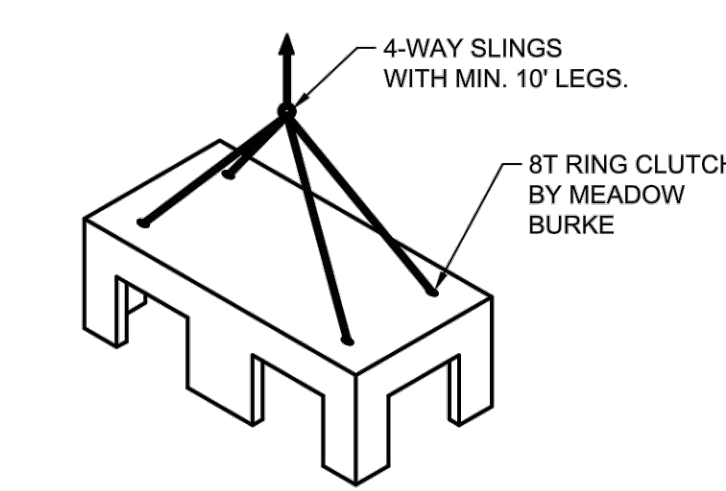

**LIFTING DETAIL**  
N.T.S.

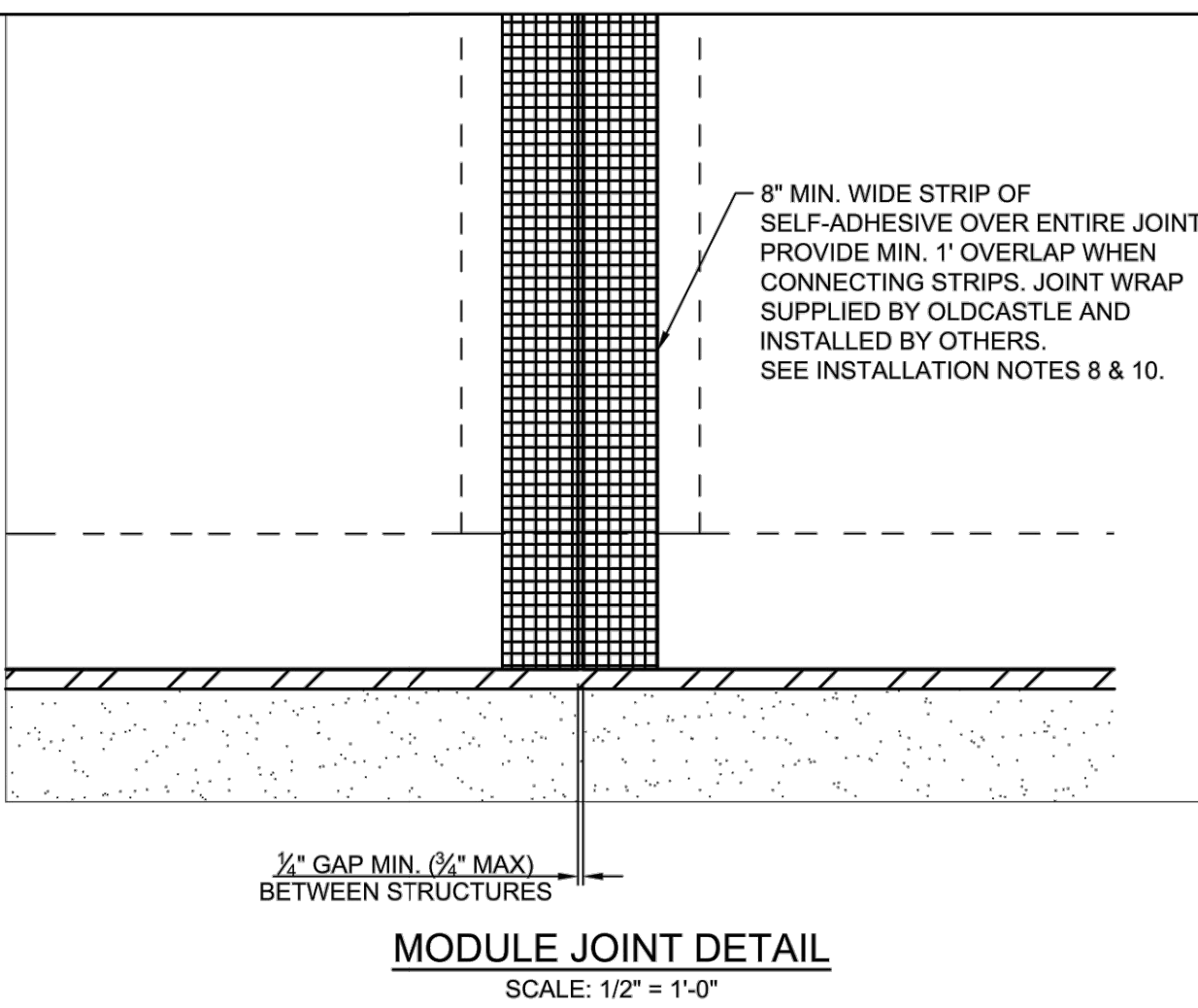

**MODULE JOINT DETAIL**  
SCALE: 1/2" = 1'-0"

REV	DESCRIPTION	DATE

**Oldcastle Infrastructure**  
A GSI COMPANY

PH: 800.678.8819 | www.oldcastleinfrastructure.com/stormcapture

THIS DOCUMENT IS THE PROPERTY OF OLDCASTLE INFRASTRUCTURE, INC. IT IS CONFIDENTIAL, SUBMITTED FOR REFERENCE PURPOSES ONLY AND SHALL NOT BE USED IN ANY WAY INJURIOUS TO THE INTERESTS OF, OR WITHOUT THE WRITTEN PERMISSION OF OLDCASTLE INFRASTRUCTURE, INC. COPYRIGHT © 2021 OLDCASTLE INFRASTRUCTURE, INC. ALL RIGHTS RESERVED.

STORMCAPTURE®	SYSTEM ID
DETENTION SYSTEM	1

CUSTOMER:  
HL Engineering

JOB NAME:  
7810 79th Ave SE

DATE	SALES	DRAWN	ENGINEER	CHECKED	SALES ORDER
9/15/2022	-	-	-	-	-

DRAWING NAME:  
SC1 7-0

JOB NUMBER:  
-

3 OF 3

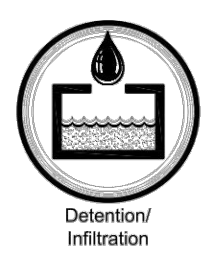

DESIGN	HL	
DRAWN	HL	
CHECKED	HL	
SHEET ISSUE DATE	03.07.2022	
<b>DRAWING SETS</b>		
PRE-APPLICATION	09/23/21	
PERMIT	03/07/22	
SET TITLE	DATE	
SET TITLE	DATE	
<b>REVISIONS</b>		
#	DATE	DESCRIPTION
1	07.29.22	BLDG PERMIT REV 01
2	09.21.22	BLDG PERMIT REV 02

**HL ENGINEERING**

6040 California Ave SW  
Suite C  
Seattle, WA 98136

**BRINDLEY RESIDENCE**

ADDRESS T.B.D.  
7810 - 79th AVE SE  
MERCER ISLAND,  
WA 98040

PERMIT DRAWINGS  
**Stormwater Detention System Details**



**25-SA OIL WATER SEPERATOR**  
100 Gallon capacity

**25-SA**

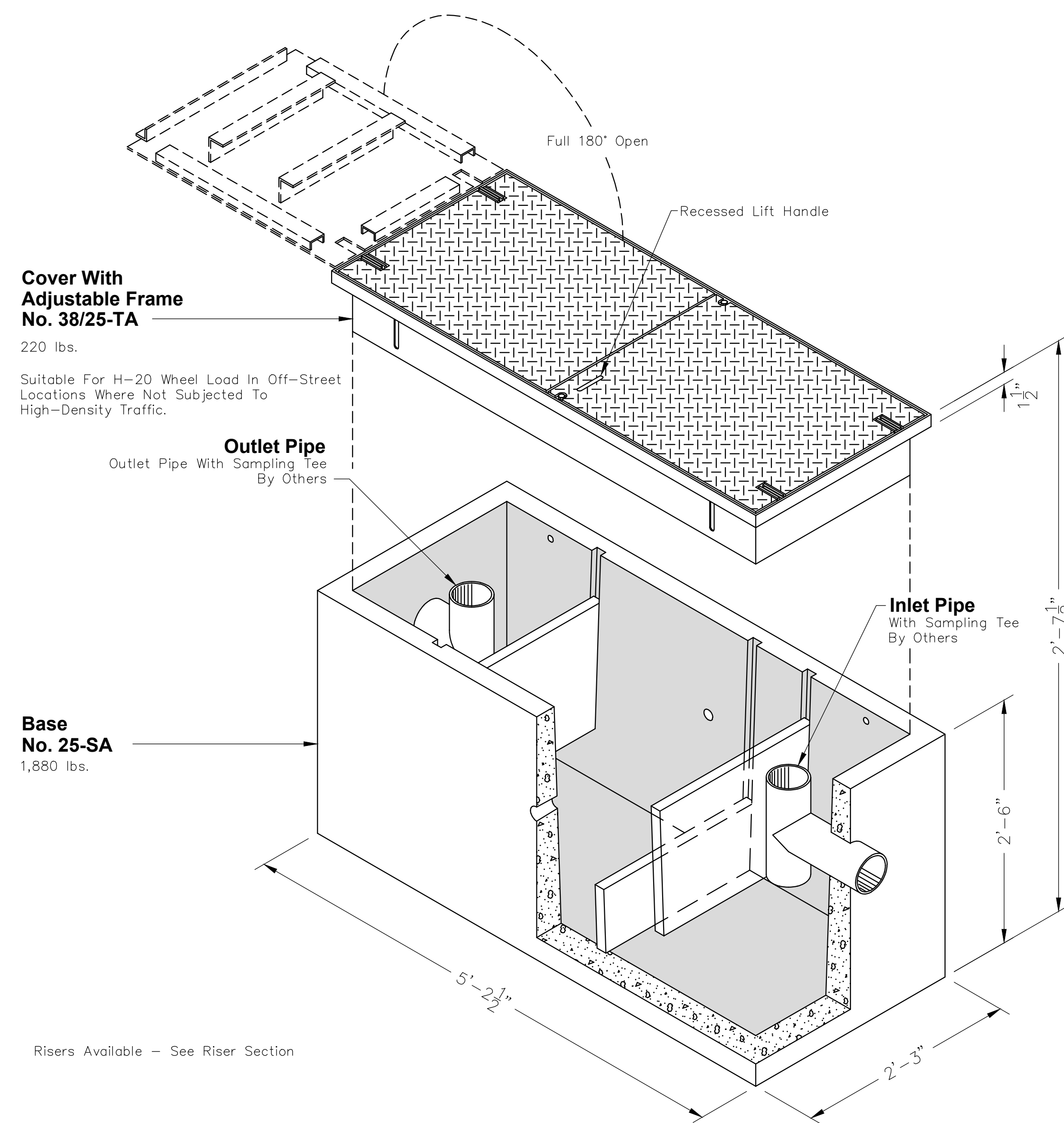

Non Skid Covers Available  
**FOR DETAILS, SEE REVERSE>>**

Items Shown Are Subject To Change Without Notice  
Issue Date: April 2016

133

© 1980–2016 Oldcastle Precast, Inc.

Mailing Address  
PO Box 588  
Auburn, WA 98071

Phone: 800-892-1538  
Fax: 253-735-4201  
Email: opauburn@oldcastle.com

**opauburn.com**

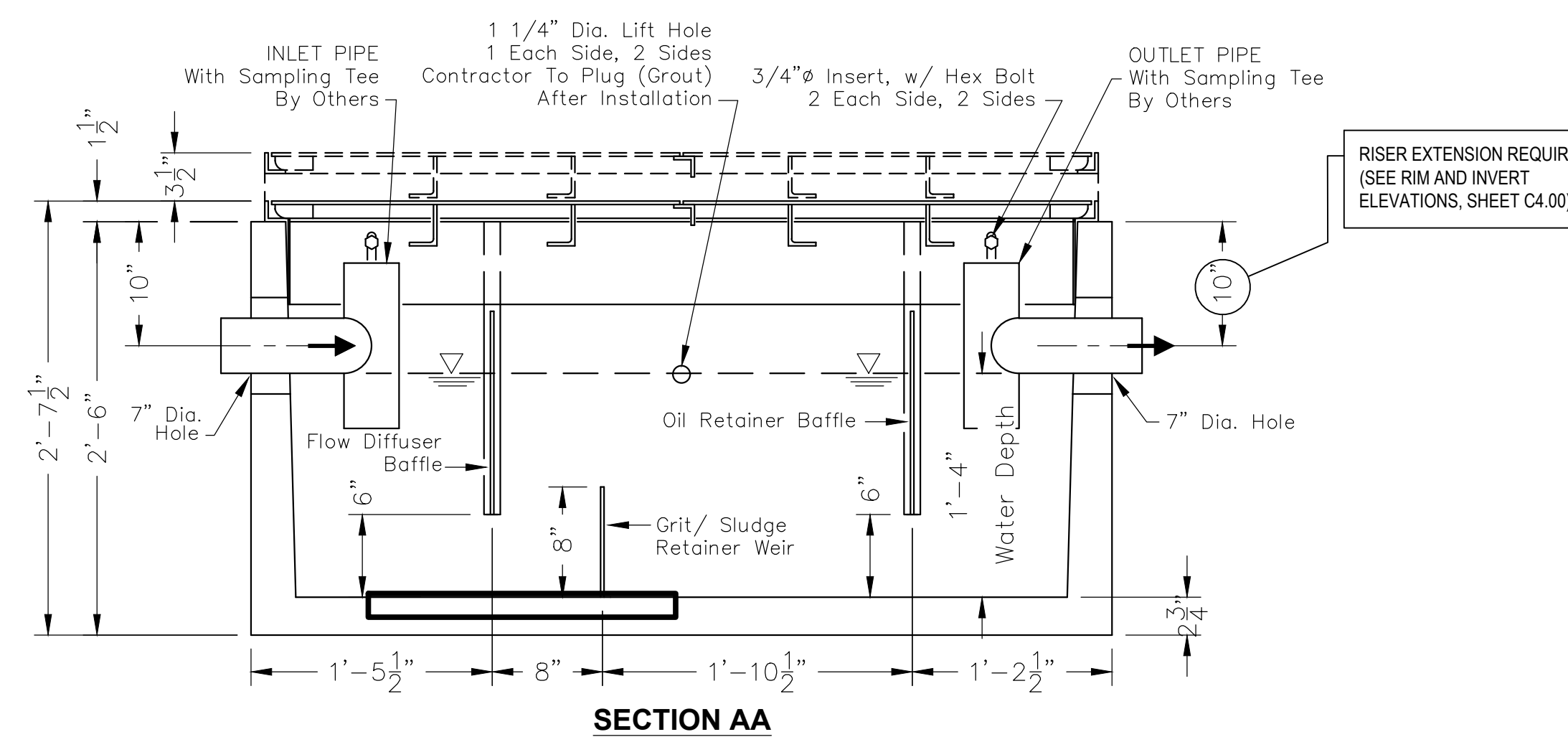
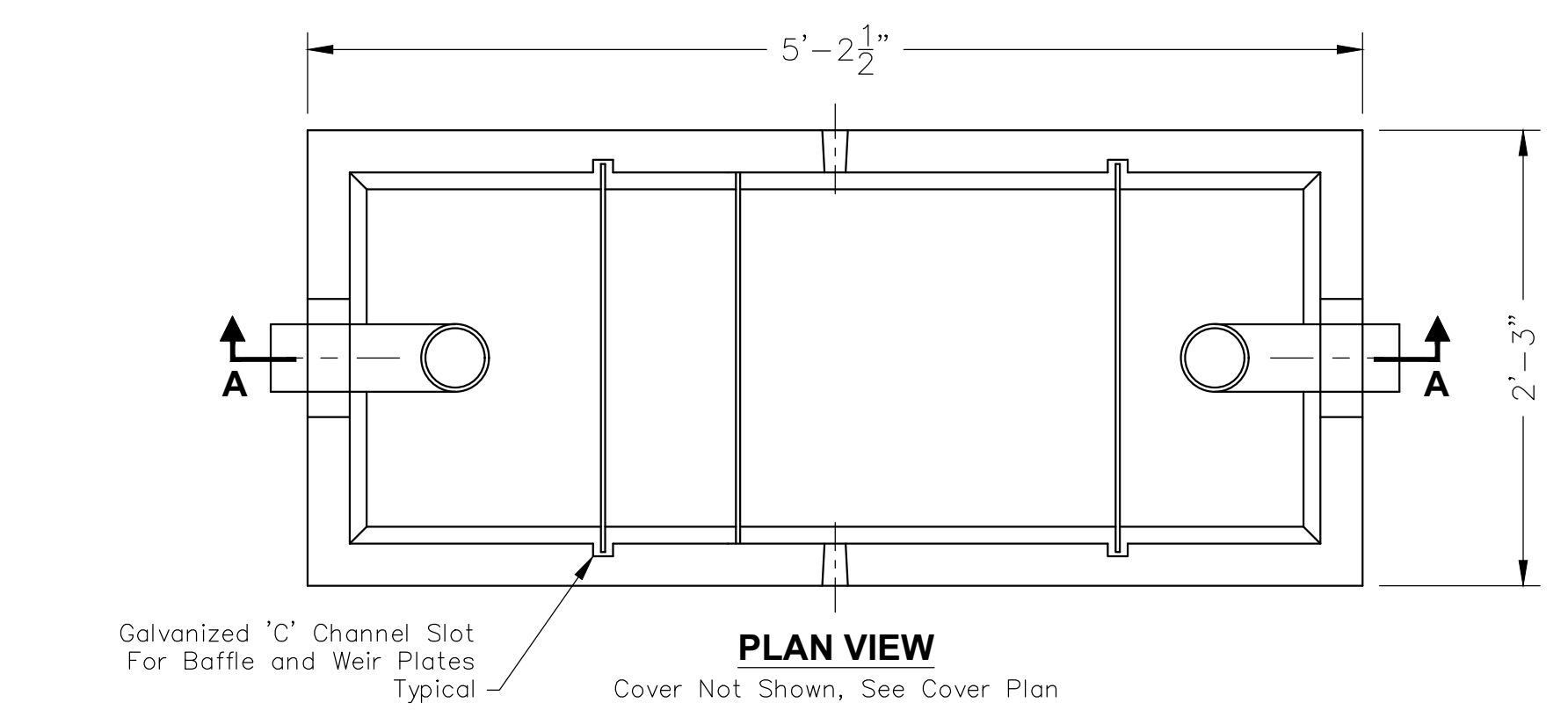

**STRUCTURAL NOTES:**

- Concrete: 28 Day Compressive Strength  $f'_c = 7000$  psi
- Rebar: ASTM A-615 Grade 60
- Mesh: ASTM A-185 Grade 65
- Design: ACI-318-05 Building Code
- Loads: HS-20 Truck Wheel w/ 30% Impact Per AASHTO

**GENERAL NOTES:**

- All Baffles and Weirs To Be Steel
- Contractor to:  
Supply and Install All Piping & Sampling Tees  
Grout In All Pipes  
Fill With Clean Water Prior To "Start-Up" Of System  
Verify All Blockout Sizes and Locations

FOR CUSTOM APPLICATIONS  
THE FOLLOWING INFORMATION IS NEEDED:  
Top Of Separator Elevation:  
Inlet Pipe Size:  
Inlet Pipe Elevation:  
Outlet Pipe Size:  
Outlet Pipe Elevation:

SCALE: 3/4"=1'-0"

133.1

© 1980–2016 Oldcastle Precast, Inc.

DETAIL: STORMWATER OIL / WATER SEPARATION SYSTEM  
NTS

DETAIL NO.: 1  
REF SHEET: C4.00

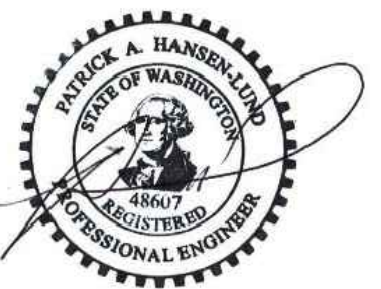

9-21-2022

DESIGN	HL	
DRAWN	HL	
CHECKED	HL	
SHEET ISSUE DATE	03.07.2022	
<b>DRAWING SETS</b>		
PRE-APPLICATION	09/23/21	
PERMIT	03/07/22	
SET TITLE	DATE	
SET TITLE	DATE	
<b>REVISIONS</b>		
#	DATE	DESCRIPTION
1	07.29.22	BLDG PERMIT REV 01
2	09.21.22	BLDG PERMIT REV 02

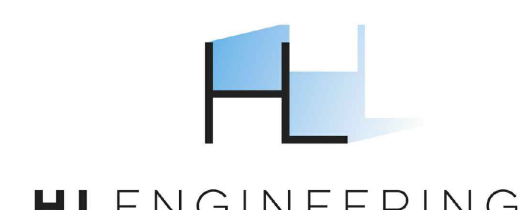

6040 California Ave SW  
Suite C  
Seattle, WA 98136

**BRINDLEY RESIDENCE**

ADDRESS T.B.D.  
7810 - 79th AVE SE  
MERCER ISLAND,  
WA 98040

PERMIT DRAWINGS  
**Stormwater Control Details**

**C4.70**

## APPENDIX E: Stormwater Pump System Calculations

# STORMWATER PUMP DESIGN

Project Name: Brindley Residence  
 Project Address: 78xx 79th Ave SE, Mercer Island, WA

Pump MH Inflow IE = 308.90  
 Pump MH Outlet IE = 316.77  
 Required Lift = 7.87 ft

**Legend:**

= Value to be provided

= Value automatically calculated

## Calculate Stormwater Flow Rates (Modeled in WWHM)

100-Yr Flow Rate (from WWHM) = 0.061 cfs  
 Convert to GPM = 27.38 gpm

Proposed Outlet Pipe Dia = 2.00 in

## Use Hazen-Williams equation to estimate frictional head loss

Hazen-Williams roughness coefficient = 150  
 Volume of flow = 27.38 gpm  
 Wetted Perimeter of outlet pipe = 6.28 in  
 Inside hydraulic dia of outlet pipe = 2.00 in  
 Frictional Head Loss per foot = 1.55 ft per foot  
 Length of pressurized pipe = 10 ft  
 Additional Equivalent Length Due to Fittings = 0 ft  
 Total Frictional Head Loss = 15.49 ft

Total Dynamic Head = 23.36 ft

## Check flow velocity is between 2 fps and 8 fps

Volume of flow = 0.0610 cfs  
 Internal cross sectional area of pipe = 0.02 sq ft  
 Velocity = 2.80 fps

## APPENDIX 2: EQUIVALENT LENGTH OF TUBING FOR FRICTION LOSS IN VALVES AND FITTINGS

TABLE 13.2A EQUIVALENT LENGTH IN FEET OF TUBING FOR FRICTION LOSS IN VALVES AND FITTINGS (TUBING).

Fitting or Valve	Equivalent Feet of Pipe for Various Nominal Diameters							
	½ in	¾ in	1 in	1¼ in	1½ in	2 in	2½ in	3 in
45° elbow (wrought)	0.5	0.5	1.0	1.0	2.0	2.0	3.0	4.0
90° elbow (wrought)	0.5	1.0	1.0	2.0	2.0	2.0	2.0	3.0
Tee, straight run (wrought)	0.5	0.5	0.5	0.5	1.0	1.0	2.0	—
Tee, branch (wrought)	1.0	2.0	3.0	4.0	5.0	7.0	9.0	—
45° elbow (cast)	0.5	1.0	2.0	2.0	3.0	5.0	8.0	11.0
90° elbow (cast)	1.0	2.0	4.0	5.0	8.0	11.0	14.0	18.0
Tee, straight run (cast)	0.5	0.5	0.5	1.0	1.0	2.0	2.0	2.0
Tee, branch (cast)	2.0	3.0	5.0	7.0	9.0	12.0	16.0	20.0
Compression stop	13.0	21.0	30.0	—	—	—	—	—
Globe valve	—	—	—	53.0	66.0	90.0	—	—
Gate valve	—	—	1.0	1.0	2.0	2.0	2.0	2.0

Conclusion: Liberty Pumps 250 Series or Approval Equal

# 250-SERIES

Submersible Sump/Effluent Pump

# Liberty Pumps®

A Family and Employee Owned Company

## 1/3 hp 1-1/2" Discharge 1/2" Solids Handling

Rugged and dependable heavy-duty cast iron pump with powder coat finish.

### Features

- Unique one-piece cast body eliminates motor housing seal ring
- Durable epoxy powder coat finish
- Vortex style impeller
- Permanently sealed and lubricated bearings
- Quick-connect 10' standard power cord allows replacement of cord in seconds without breaking seals to motor (other lengths available)
- Heavy-duty Vertical Magnetic Float (VMF) on vertical float switch models

### Models

- 250** Manual
- 251** Wide-Angle Float switch
- 253** Wide-Angle Float switch, Series Plug
- 257** VMF, Vertical Magnetic Float switch

Wide-angle float switches are mercury-free, mechanically activated.



Available with  
Wide-Angle  
Float Switch and  
Piggyback Plug



# innovate. evolve.

# 250-Series

## Impeller

Vortex style engineered polymer

## Paint

Powder coat

## Max Fluid Temperature

140°F (60°C) Intermittent  
104°F (40°C) Continuous duty

## Power Cord Type

SJTW (10' and 25' models)  
SJTOOW (35' and 50' models)

## Motor Housing

Class 25 cast iron

## Shaft

Stainless

## Hardware

Stainless

## Mechanical Shaft Seal

Engineered double lip seal

## Bearings

Upper and lower ball bearings

## Dimensional Data

**Weight:** 20 lbs (Model 257)  
**Height:** 10-1/2"  
**Major Width:** 9-3/5" (Model 250)

## Motor Specifications

1/3 hp 115V 5.2A  
Thermally protected and permanently lubricated  
Permanent Split Capacitor (PSC)

## Cord Lengths

MODEL	10'	25'[-2]	35'[-3]	50'[-5]
250	Standard	Optional	Optional	Optional
251	Standard	Optional	Optional	Optional
253	Standard	Optional	Optional	N/A
257	Standard	Optional	N/A	N/A

10' cord length standard on all models. For optional lengths, add "-2, -3 or -5" suffix to model number.  
Example: for model 250 with 35' cord, order 250-3

## Performance Curve

60 Hz, 3450 RPM

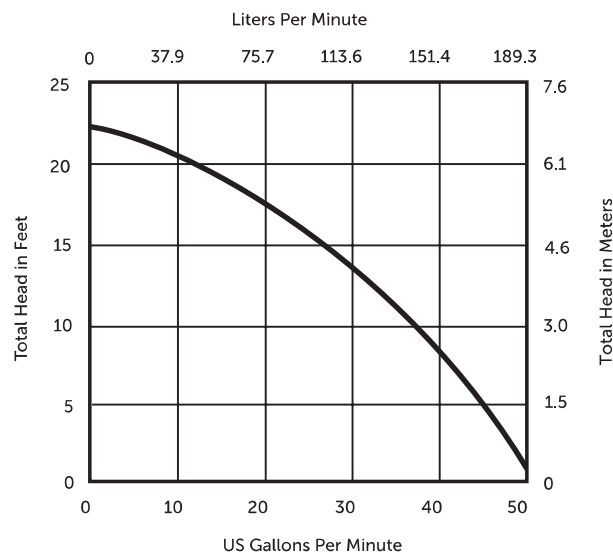

## Effluent Models



**Model 250**  
Manual, no float switch

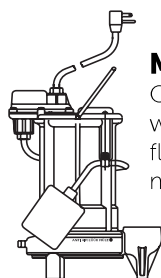

**Model 251**  
Quick-connect wide-angle float switch, mercury-free

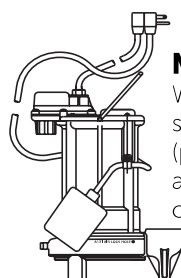

**Model 253**  
Wide-angle float switch with series (piggyback) plug, allows manual operation of pump

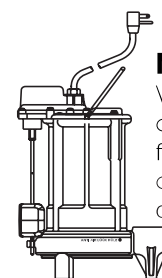

**Model 257**  
VMF, magnetically operated vertical float switch – operates in a 10" diameter sump

## APPENDIX F: Operations and Maintenance Standards

**Table V-A.3: Maintenance Standards - Closed Detention Systems (Tanks/Vaults)**

Maintenance Component	Defect	Conditions When Maintenance is Needed	Results Expected When Maintenance is Performed
Storage Area	Plugged Air Vents	One-half of the cross section of a vent is blocked at any point or the vent is damaged.	Vents open and functioning.
	Debris and Sediment	Accumulated sediment depth exceeds 10% of the diameter of the storage area for 1/2 length of storage vault or any point depth exceeds 15% of diameter.  (Example: 72-inch storage tank would require cleaning when sediment reaches depth of 7 inches for more than 1/2 length of tank.)	All sediment and debris removed from storage area.
	Joints Between Tank/Pipe Section	Any openings or voids allowing material to be transported into facility.  (Will require engineering analysis to determine structural stability).	All joint between tank/pipe sections are sealed.
	Tank Pipe Bent Out of Shape	Any part of tank/pipe is bent out of shape more than 10% of its design shape. (Review required by engineer to determine structural stability).	Tank/pipe repaired or replaced to design.
	Vault Structure Includes Cracks in Wall, Bottom, Damage to Frame and/or Top Slab	Cracks wider than 1/2-inch and any evidence of soil particles entering the structure through the cracks, or maintenance/inspection personnel determines that the vault is not structurally sound.  Cracks wider than 1/2-inch at the joint of any inlet/outlet pipe or any evidence of soil particles entering the vault through the walls.	Vault replaced or repaired to design specifications and is structurally sound.  No cracks more than 1/4-inch wide at the joint of the inlet/outlet pipe.



**Table V-A.3: Maintenance Standards - Closed Detention Systems (Tanks/Vaults)**

Maintenance Component	Defect	Conditions When Maintenance is Needed	Results Expected When Maintenance is Performed
Manhole	Cover Not in Place	Cover is missing or only partially in place. Any open manhole requires maintenance.	Manhole is closed.
	Locking Mechanism Not Working	Mechanism cannot be opened by one maintenance person with proper tools. Bolts into frame have less than 1/2 inch of thread (may not apply to self-locking lids).	Mechanism opens with proper tools.
	Cover Difficult to Remove	One maintenance person cannot remove lid after applying normal lifting pressure. Intent is to keep cover from sealing off access to maintenance.	Cover can be removed and reinstalled by one maintenance person.
	Ladder Rungs Unsafe	Ladder is unsafe due to missing rungs, misalignment, not securely attached to structure wall, rust, or cracks.	Ladder meets design standards. Allows maintenance person safe access.
Catch Basins	See <a href="#">Table V-A.5: Maintenance Standards - Catch Basins</a>	See <a href="#">Table V-A.5: Maintenance Standards - Catch Basins</a>	See <a href="#">Table V-A.5: Maintenance Standards - Catch Basins</a>

**Table V-A.4: Maintenance Standards - Control Structure/Flow Restrictor**

Maintenance Component	Defect	Condition When Maintenance is Needed	Results Expected When Maintenance is Performed
General	Trash and Debris (Includes Sediment)	Material exceeds 25% of sump depth or 1 foot below orifice plate.	Control structure orifice is not blocked. All trash and debris removed.
	Structural Damage	<p>Structure is not securely attached to manhole wall.</p> <p>Structure is not in upright position (allow up to 10% from plumb).</p> <p>Connections to outlet pipe are not watertight and show signs of rust.</p> <p>Any holes - other than designed holes - in the structure.</p>	<p>Structure securely attached to wall and outlet pipe.</p> <p>Structure in correct position.</p> <p>Connections to outlet pipe are water tight; structure repaired or replaced and works as designed.</p> <p>Structure has no holes other than designed holes.</p>
Cleanout Gate	Damaged or Missing	<p>Cleanout gate is not watertight or is missing.</p> <p>Gate cannot be moved up and down by one maintenance person.</p> <p>Chain/rod leading to gate is missing or damaged.</p>	<p>Gate is watertight and works as designed.</p> <p>Gate moves up and down easily and is watertight.</p> <p>Chain is in place and works as designed.</p> <p>Gate is repaired or replaced to meet design standards.</p>

**Table V-A.4: Maintenance Standards - Control Structure/Flow Restrictor**

Maintenance Component	Defect	Condition When Maintenance is Needed	Results Expected When Maintenance is Performed
		Gate is rusted over 50% of its surface area.	
Orifice Plate	Damaged or Missing	Control device is not working properly due to missing, out of place, or bent orifice plate.	Plate is in place and works as designed.
	Obstructions	Any trash, debris, sediment, or vegetation blocking the plate.	Plate is free of all obstructions and works as designed.
Overflow Pipe	Obstructions	Any trash or debris blocking (or having the potential of blocking) the overflow pipe.	Pipe is free of all obstructions and works as designed.
Manhole	See <a href="#">Table V-A.3: Maintenance Standards - Closed Detention Systems (Tanks/Vaults)</a>	See <a href="#">Table V-A.3: Maintenance Standards - Closed Detention Systems (Tanks/Vaults)</a>	See <a href="#">Table V-A.3: Maintenance Standards - Closed Detention Systems (Tanks/Vaults)</a>
Catch Basin	See <a href="#">Table V-A.5: Maintenance Standards - Catch Basins</a>	See <a href="#">Table V-A.5: Maintenance Standards - Catch Basins</a>	See <a href="#">Table V-A.5: Maintenance Standards - Catch Basins</a>

**Table V-A.16: Maintenance Standards - Baffle Oil/Water Separators (API Type)**

Maintenance Component	Defect	Condition When Maintenance is Needed	Results Expected When Maintenance is Performed
General	Monitoring	Inspection of discharge water for obvious signs of poor water quality.	Effluent discharge from vault should be clear with out thick visible sheen.
	Sediment Accumulation	Sediment depth in bottom of vault exceeds 6-inches in depth.	No sediment deposits on vault bottom that would impede flow through the vault and reduce separation efficiency.
	Trash and Debris Accumulation	Trash and debris accumulation in vault, or pipe inlet/outlet, floatables and non-floatables.	Trash and debris removed from vault, and inlet/outlet piping.
	Oil Accumulation	Oil accumulations that exceed 1-inch, at the surface of the water.	Extract oil from vault by vactoring. Disposal in accordance with state and local rules and regulations.
	Damaged Pipes	Inlet or outlet piping damaged or broken and in need of repair.	Pipe repaired or replaced.

**Table V-A.16: Maintenance Standards - Baffle Oil/Water Separators (API Type)**

Maintenance Component	Defect	Condition When Maintenance is Needed	Results Expected When Maintenance is Performed
	Access Cover Damaged/Not Working	Cover cannot be opened, corrosion/deformation of cover.	Cover repaired to proper working specifications or replaced.
	Vault Structure Damage - Includes Cracks in Walls Bottom, Damage to Frame and/or Top Slab	See <a href="#">Table V-A.5: Maintenance Standards - Catch Basins</a>  Cracks wider than 1/2-inch at the joint of any inlet/outlet pipe or evidence of soil particles entering through the cracks.	Vault replaced or repairs made so that vault meets design specifications and is structurally sound.  Vault repaired so that no cracks exist wider than 1/4-inch at the joint of the inlet/outlet pipe.
	Baffles	Baffles corroding, cracking, warping and/or showing signs of failure as determined by maintenance/inspection person.	Baffles repaired or replaced to specifications.
	Access Ladder Damaged	Ladder is corroded or deteriorated, not functioning properly, not securely attached to structure wall, missing rungs, cracks, and misaligned.	Ladder replaced or repaired and meets specifications, and is safe to use as determined by

**Table V-A.16: Maintenance Standards - Baffle Oil/Water Separators (API Type)**

<b>Maintenance Component</b>	<b>Defect</b>	<b>Condition When Maintenance is Needed</b>	<b>Results Expected When Maintenance is Performed</b>
			inspection personnel.